

Grizzly **Industrial, Inc.**®

MODEL G0605X/G0606X EXTREME SERIES 12" TABLE SAW OWNER'S MANUAL



COPYRIGHT © OCTOBER, 2006 BY GRIZZLY INDUSTRIAL, INC. REVISED DECEMBER, 2009 (BL)
**WARNING: NO PORTION OF THIS MANUAL MAY BE REPRODUCED IN ANY SHAPE
OR FORM WITHOUT THE WRITTEN APPROVAL OF GRIZZLY INDUSTRIAL, INC.**
(FOR MODELS MANUFACTURED SINCE 11/06) #BL8591 PRINTED IN TAIWAN

 **WARNING!**

This manual provides critical safety instructions on the proper setup, operation, maintenance and service of this machine/equipment.

Failure to read, understand and follow the instructions given in this manual may result in serious personal injury, including amputation, electrocution or death.

The owner of this machine/equipment is solely responsible for its safe use. This responsibility includes but is not limited to proper installation in a safe environment, personnel training and usage authorization, proper inspection and maintenance, manual availability and comprehension, application of safety devices, blade/cutter integrity, and the usage of personal protective equipment.

The manufacturer will not be held liable for injury or property damage from negligence, improper training, machine modifications or misuse.

 **WARNING!**

Some dust created by power sanding, sawing, grinding, drilling, and other construction activities contains chemicals known to the State of California to cause cancer, birth defects or other reproductive harm. Some examples of these chemicals are:

- **Lead from lead-based paints.**
- **Crystalline silica from bricks, cement and other masonry products.**
- **Arsenic and chromium from chemically-treated lumber.**

Your risk from these exposures varies, depending on how often you do this type of work. To reduce your exposure to these chemicals: Work in a well ventilated area, and work with approved safety equipment, such as those dust masks that are specially designed to filter out microscopic particles.

Table of Contents

- INTRODUCTION..... 3**
 - Foreword 3
 - Contact Info 3
 - G0605X Data Sheet 4
 - G0606X Data Sheet 5
 - Identification 6
- SECTION 1: SAFETY 7**
 - Safety Instructions for Machinery 7
 - Safety Instructions for Table Saws 9
 - Preventing Kickback..... 10
 - Protecting Yourself From Kickback..... 10
 - Glossary of Terms 11
- SECTION 2: CIRCUIT REQUIREMENTS 12**
 - Operation..... 12
 - 440V Conversion..... 13
- SECTION 3: SET UP 14**
 - Set Up Safety 14
 - Items Needed for Set Up 14
 - Unpacking 14
 - Machine Inventory 15
 - Fence Inventory..... 15
 - Fence Rail Inventory 15
 - Extension Table Inventory..... 16
 - Outfeed Table Inventory..... 16
 - Hardware Recognition Chart..... 17
 - Clean Up 18
 - Site Considerations 18
 - Extension Table..... 19
 - Outfeed Table..... 21
 - Saw Blade 22
 - Arbor..... 23
 - Table Insert 23
 - Blade Guard and Splitter 24
 - Riving Knife 25
 - On/Off Switch 25
 - Miter Gauge..... 25
 - Fence Components 26
 - Dust Collection 26
 - Recommended Adjustments 27
 - Test Run..... 27

SECTION 4: OPERATIONS	29
Operation Safety	29
Basic Controls	29
Disabling On/Off Switch	30
Blade Selection	30
Workpiece Inspection	32
Non-Through & Through Cuts.....	32
Ripping	33
Crosscutting	34
Miter Cuts	34
Blade Tilt/Bevel Cuts.....	35
Dado Cutting	35
Rabbet Cutting	37
Resawing.....	39
SECTION 5: ACCESSORIES	43
SECTION 6: MAINTENANCE.....	45
Schedule	45
Cleaning	45
Lubrication.....	45
SECTION 7: SERVICE	46
Troubleshooting.....	46
Replacing Flat Belt.....	48
Blade Tilt Stops	50
Digital Readout.....	51
Miter Slot to Blade.....	52
Parallelism.....	52
Blade Alignment	54
Adjusting Fence.....	54
Miter Gauge.....	55
G0605X/G0606X Electrical Components.....	56
G0605X Wiring Diagram	57
G0606X Electrical Components	58
G0606X Wiring Diagram 220V.....	59
G0606X Wiring Diagram 440V.....	60
Cabinet, Motor & Main Table Breakdown	61
Blade Guard Assembly Breakdown	64
Fence Assembly Breakdown.....	65
Miter Gauge Assembly Breakdown.....	66
Extension Table Assembly Breakdown.....	67
Outfeed Table Assembly Breakdown.....	68
Warning Label Parts List.....	69
WARRANTY AND RETURNS	70

INTRODUCTION

Foreword

We are proud to offer the Model G0605X/G0606X Extreme Series 12" Table Saw. This machine is part of a growing Grizzly family of fine wood-working machinery. When used according to the guidelines set forth in this manual, you can expect years of trouble-free, enjoyable operation and proof of Grizzly's commitment to customer satisfaction.

We are pleased to provide this manual with the Model G0605X/G0606X. It was written to guide you through assembly, review safety considerations, and cover general operating procedures. It represents our effort to produce the best documentation possible.

The specifications, drawings, and photographs illustrated in this manual represent the Model G0605X/G0606X as supplied when the manual was prepared. However, owing to Grizzly's policy of continuous improvement, changes may be made at any time with no obligation on the part of Grizzly. For your convenience, we always keep current Grizzly manuals available on our website at **www.grizzly.com**. Any updates to your machine will be reflected in these manuals as soon as they are complete. Visit our site often to check for the latest updates to this manual!

Contact Info

If you have any comments regarding this manual, please write to us at the address below:

Grizzly Industrial, Inc.
c/o Technical Documentation Manager
P.O. Box 2069
Bellingham, WA 98227-2069
Email: manuals@grizzly.com

We stand behind our machines. If you have any service questions or parts requests, please call or write us at the location listed below.

Grizzly Industrial, Inc.
1203 Lycoming Mall Circle
Muncy, PA 17756
Phone: (570) 546-9663
Fax: (800) 438-5901
E-Mail: techsupport@grizzly.com
Web Site: <http://www.grizzly.com>





MACHINE DATA SHEET

Customer Service #: (570) 546-9663 • To Order Call: (800) 523-4777 • Fax #: (800) 438-5901

MODEL G0605X 12" EXTREME SERIES TABLE SAW

Overall Dimensions:

Table Height.....	35 ³ / ₄ "
Table Size30 ³ / ₄ " D x 24 ¹ / ₂ " W
Table Size w/Extension.....	.30 ³ / ₄ " D x 78 ³ / ₄ " W
Overall Size when Fully Assembled.....	91" W x 80 ¹ / ₂ " L x 42 ¹ / ₂ "H
Miter Gauge T-Slot.....	. ³ / ₄ " W x ³ / ₈ " D
Blade Tilt	Left 0-45°
Shipping Weight (5 Boxes)	967 lbs.
Machine Weight	715 lbs.
Footprint	58 ¹ / ₂ " W x 66 ¹ / ₂ " L

Cutting Capacities:

Blade Size	12"
Maximum Depth Of Cut @ 90°	4"
Maximum Depth Of Cut @ 45°	2 ³ / ₄ "
Maximum Rip Capacity To Right Of Blade	52"
Distance From Front Of Table To Center Of Blade	17 ¹ / ₄ "
Distance From Front Of Table To Front Of Blade	13 ¹ / ₂ "
Maximum Width Of Dado Cut	1"

Motor:

Type	TEFC Capacitor Start Induction
Horsepower	5 HP
Phase/Cycle	Single-Phase/60 Hz
Voltage	220V
Amps	23A
RPM	3450
Power Transfer.....	Belt Drive
Power Switch	On/Off Push Button, Magnetic

Construction:

Main Table	Precision-Ground Cast Iron
Cabinet.....	Pre-Formed Steel
Miter Gauge	Aluminum Body/Steel Miter Bar
Trunnions	Cast Iron
Bearings	Sealed & Permanently Lubricated
Fence	T-Shape, Front Locking, Aluminum Extruded Body

Arbor Shaft:

Dimensions.....	1" Diameter
Speed.....	3600 RPM

Features:

- Included Outfeed & Extension Tables w/Storage Shelves
- Digital Tilt Gauge
- Riving Knife
- Hinged Motor Cover
- 4" Dust Port
- Included 12" Blade

Specifications, while deemed accurate, are not guaranteed.





MACHINE DATA SHEET

Customer Service #: (570) 546-9663 • To Order Call: (800) 523-4777 • Fax #: (800) 438-5901

MODEL G0606X 12" EXTREME SERIES TABLE SAW

Overall Dimensions:

Table Height.....	35 ³ / ₄ "
Table Size30 ³ / ₄ " D x 24 ¹ / ₂ " W
Table Size w/Extension.....	.30 ³ / ₄ " D x 78 ³ / ₄ " W
Overall Size when Fully Assembled.....	91" W x 80 ¹ / ₂ " L x 42 ¹ / ₂ "H
Miter Gauge T-Slot.....	. ³ / ₄ " W x ³ / ₈ " D
Blade Tilt	Left 0-45°
Shipping Weight (5 Boxes)	967 lbs.
Machine Weight	715 lbs.
Footprint	58 ¹ / ₂ " W x 66 ¹ / ₂ " L

Cutting Capacities:

Blade Size	12"
Maximum Depth Of Cut @ 90°	4"
Maximum Depth Of Cut @ 45°	2 ³ / ₄ "
Maximum Rip Capacity To Right Of Blade	52"
Distance From Front Of Table To Center Of Blade	17 ¹ / ₄ "
Distance From Front Of Table To Front Of Blade	13 ¹ / ₂ "
Maximum Width Of Dado Cut	1"

Motor:

Type	TEFC Induction
Horsepower	7 ¹ / ₂ HP
Phase/Cycle	3-Phase/60 Hz
Voltage	220V/440V
Prewired Voltage	220V
Amps	19/10A
RPM	3450
Power Transfer.....	Belt Drive
Power Switch	On/Off Push Button, Magnetic

Construction:

Main Table	Precision-Ground Cast Iron
Cabinet.....	Pre-Formed Steel
Miter Gauge	Aluminum Body/Steel Miter Bar
Trunnions	Cast Iron
Bearings	Sealed & Permanently Lubricated
Fence	T-Shape, Front Locking, Aluminum Extruded Body

Arbor Shaft:

Dimensions.....	1" Diameter
Speed.....	3600 RPM

Features:

- Included Outfeed & Extension Tables w/Storage Shelves
- Digital Tilt Gauge
- Riving Knife
- Hinged Motor Cover
- 4" Dust Port
- Included 12" Blade

Specifications, while deemed accurate, are not guaranteed.



Identification

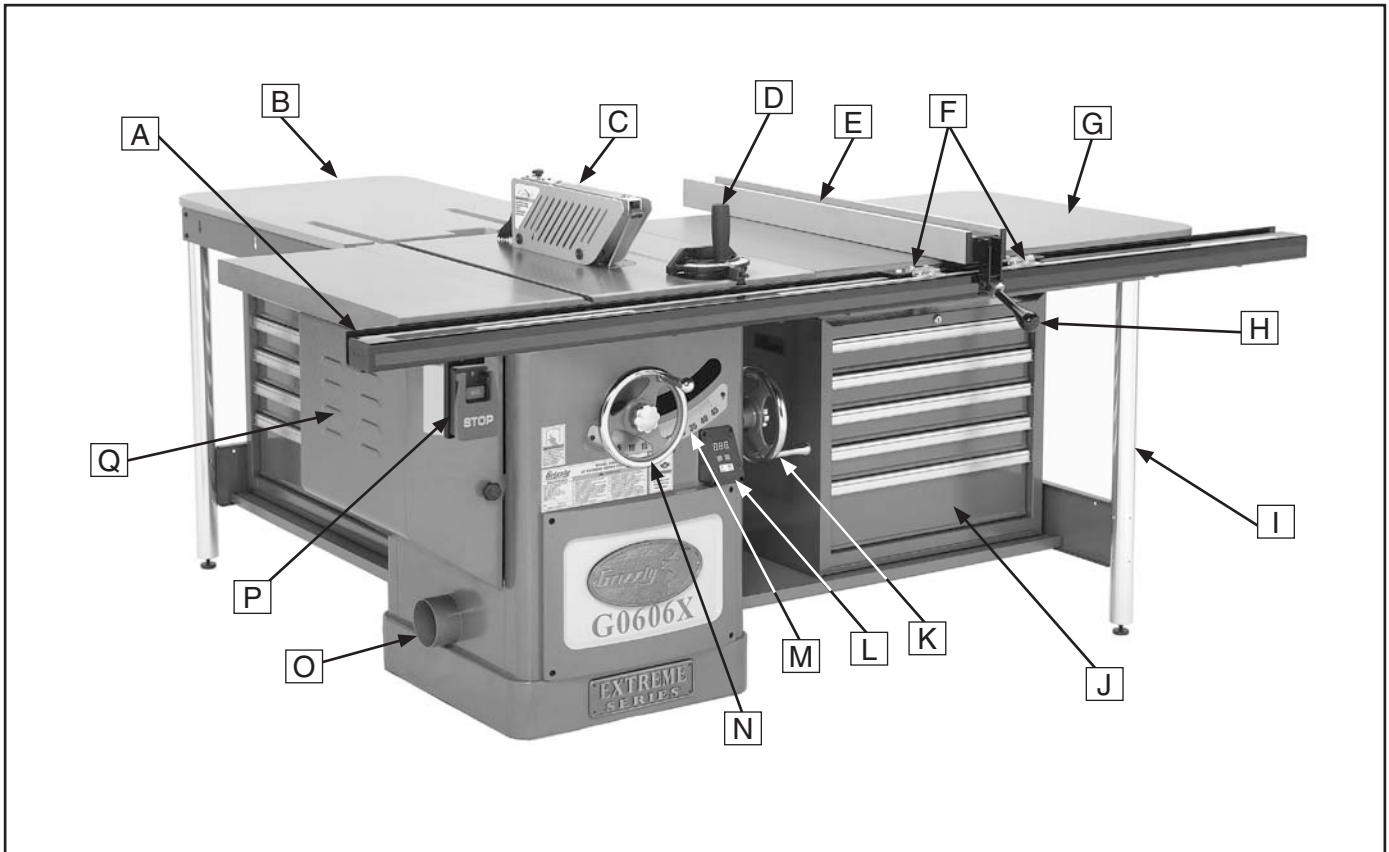

Figure 1. G0606X identification.

- | | |
|--|---|
| A. Front Rail | J. Tool Chest (Optional) |
| B. Outfeed Table | K. Blade Tilt Handwheel & Lock |
| C. Blade Guard and Splitter | L. Blade Angle Digital Readout |
| D. Miter Gauge | M. Blade Tilt Scale |
| E. Fence | N. Blade Height Handwheel |
| F. Fence Scale Indicator | O. Dust Port |
| G. Front (Main) Extension Table | P. ON/OFF Switch w/Emergency STOP Paddle |
| H. Fence Lock Handle | Q. Motor Cover |
| I. Support Leg | |



SECTION 1: SAFETY

WARNING

For Your Own Safety, Read Instruction Manual Before Operating this Machine

The purpose of safety symbols is to attract your attention to possible hazardous conditions. This manual uses a series of symbols and signal words intended to convey the level of importance of the safety messages. The progression of symbols is described below. Remember that safety messages by themselves do not eliminate danger and are not a substitute for proper accident prevention measures.



Indicates an imminently hazardous situation which, if not avoided, **WILL** result in death or serious injury.



Indicates a potentially hazardous situation which, if not avoided, **COULD** result in death or serious injury.



Indicates a potentially hazardous situation which, if not avoided, **MAY** result in minor or moderate injury. It may also be used to alert against unsafe practices.

NOTICE

This symbol is used to alert the user to useful information about proper operation of the machine.

WARNING

Safety Instructions for Machinery

- 1. READ THE ENTIRE MANUAL BEFORE STARTING MACHINERY.** Machinery presents serious injury hazards to untrained users.
- 2. MAKE SURE GUARDS ARE IN PLACE AND WORK CORRECTLY BEFORE USING MACHINERY.**
- 3. ALWAYS USE ANSI APPROVED SAFETY GLASSES WHEN OPERATING MACHINERY.** Everyday eyeglasses only have impact resistant lenses—they are NOT safety glasses.
- 4. ALWAYS WEAR A NIOSH APPROVED RESPIRATOR WHEN OPERATING MACHINERY THAT PRODUCES DUST.** Wood dust can cause severe respiratory illnesses.
- 5. ALWAYS USE HEARING PROTECTION WHEN OPERATING MACHINERY.** Machinery noise can cause permanent hearing loss.
- 6. WEAR PROPER APPAREL. DO NOT** wear loose clothing, gloves, neckties, rings, or jewelry that can catch in moving parts. Wear protective hair covering to contain long hair and wear non-slip footwear.



WARNING

Safety Instructions for Machinery

7. **NEVER OPERATE MACHINERY WHEN TIRED OR UNDER THE INFLUENCE OF DRUGS OR ALCOHOL.** Be mentally alert at all times when running machinery.
8. **ONLY ALLOW TRAINED AND PROPERLY SUPERVISED PERSONNEL TO OPERATE MACHINERY.** Make sure operation instructions are safe and clearly understood.
9. **KEEP CHILDREN AND VISITORS AWAY.** Keep all children and visitors a safe distance from the work area.
10. **MAKE WORKSHOP CHILDPROOF.** Use padlocks, master switches, and remove start switch keys.
11. **NEVER LEAVE WHEN MACHINE IS RUNNING.** Turn power **OFF** and allow all moving parts to come to a complete stop before leaving machine unattended.
12. **DO NOT USE IN DANGEROUS ENVIRONMENTS.** DO NOT use machinery in damp, wet locations, or where any flammable or noxious fumes may exist.
13. **KEEP WORK AREA CLEAN AND WELL LIGHTED.** Clutter and dark shadows may cause accidents.
14. **USE A GROUNDED EXTENSION CORD RATED FOR THE MACHINE AMPERAGE.** Grounded cords minimize shock hazards. Undersized cords create excessive heat. Always replace damaged extension cords.
15. **ALWAYS DISCONNECT FROM POWER SOURCE BEFORE SERVICING MACHINERY.** Make sure switch is in OFF position before reconnecting.
16. **MAINTAIN MACHINERY WITH CARE.** Keep blades sharp and clean for best and safest performance. Follow instructions for lubricating and changing accessories.
17. **REMOVE ADJUSTING KEYS AND WRENCHES.** Make a habit of checking for keys and adjusting wrenches before turning machinery **ON**.
18. **CHECK FOR DAMAGED PARTS BEFORE USING MACHINERY.** Check for binding or misaligned parts, broken parts, loose bolts, and any other conditions that may impair machine operation. Repair or replace damaged parts before operation.
19. **USE RECOMMENDED ACCESSORIES.** Refer to the instruction manual for recommended accessories. Improper accessories increase risk of injury.
20. **DO NOT FORCE MACHINERY.** Work at the speed for which the machine or accessory was designed.
21. **SECURE WORKPIECE.** Use clamps or a vise to hold the workpiece when practical. A secured workpiece protects your hands and frees both hands to operate the machine.
22. **DO NOT OVERREACH.** Maintain stability and balance at all times.
23. **MANY MACHINES CAN EJECT WORKPIECES TOWARD OPERATOR.** Know and avoid conditions that cause the workpiece to "kickback."
24. **ALWAYS LOCK MOBILE BASES (IF USED) BEFORE OPERATING MACHINERY.**
25. **CERTAIN DUST MAY BE HAZARDOUS** to the respiratory systems of people and animals, especially fine dust. Be aware of the type of dust you are exposed to and always wear a respirator designed to filter that type of dust.



WARNING

Safety Instructions for Table Saws

- 1. SAFETY GUARDS.** Always use the blade guard, splitter, and anti-kickback fingers on "through-sawing" operations. *The blade cuts completely through the top of the workpiece on through-sawing operations.*
- 2. KICKBACK.** Be familiar with kickback. Kickback happens when the workpiece is thrown towards the operator at a high rate of speed. *Until you have a clear understanding of kickback and how it occurs, DO NOT operate this table saw!*
- 3. REACHING OVER SAW BLADE.** Never reach behind or over the blade while the saw is running; *hands or arms could be pulled into the saw blade if kickback occurs.*
- 4. WORKPIECE CONTROL.** Make sure the workpiece is stable on the table and is supported by the rip fence or the miter gauge during cutting operations. **DO NOT** perform any cutting operations free-hand.
- 5. SAFETY ACCESSORIES.** Use push sticks, hold-downs, featherboards, and other devices to increase cutting safety.
- 6. OPERATOR POSITION.** Never stand or have any part of your body directly in-line with the cutting path of the saw blade.
- 7. COMFORTABLE POSITION.** Avoid operations and hand positions where a slip could cause your hand to move into the blade.
- 8. CROSSCUTTING OPERATIONS.** Remove the rip fence whenever using the miter gauge to crosscut a workpiece.
- 9. CUT-OFF PIECES.** Stop the blade before removing cut-off pieces.
- 10. BLADE HEIGHT.** Always adjust the blade to the proper height above the workpiece.
- 11. WORKPIECE SUPPORT.** Provide adequate support to the rear and sides of the saw table for wide or long workpieces.
- 12. DAMAGED SAW BLADES.** Never use blades that have been dropped or otherwise damaged.
- 13. DADO AND RABBIT OPERATIONS**
Dado and rabbeting operations require special attention because those operations must be performed with the blade guard removed. Be especially aware of your personal safety whenever operating saw with the guard removed, and always immediately replace the blade guard after these operations are complete.
- 14. EXPERIENCING DIFFICULTIES.** If at any time you are experiencing difficulties performing the intended operation, stop using the machine! Contact our Service Department at (570) 546-9663.

WARNING

Like all machines there is danger associated with the Model G0605X/G0606X. Accidents are frequently caused by lack of familiarity or failure to pay attention. Use this machine with respect and caution to lessen the possibility of operator injury. If normal safety precautions are overlooked or ignored, serious personal injury may occur.

CAUTION

No list of safety guidelines can be complete. Every shop environment is different. Always consider safety first, as it applies to your individual working conditions. Use this and other machinery with caution and respect. Failure to do so could result in serious personal injury, damage to equipment, or poor work results.



WARNING

Statistics show that most common accidents among table saw users can be linked to kickback. Kickback is typically defined as the high-speed expulsion of stock from the table saw toward its operator. In addition to the danger of the operator or others in the area being struck by the flying stock, it is often the case that the operator's hands are pulled into the blade during the kickback.

Preventing Kickback

Below are tips to avoid the most common causes of kickback:

- Only cut workpieces with at least one smooth and straight edge. DO NOT cut warped, cupped or twisted wood.
- Never attempt freehand cuts. If the workpiece is not fed parallel with the blade, a kickback will likely occur. Always use the rip fence or crosscut fence to support the workpiece.
- Make sure the splitter or riving knife is aligned with the blade. A misaligned splitter can cause the workpiece to catch or bind, increasing the chance of kickback. If you think that your splitter is not aligned with the blade, check it immediately!
- Take the time to check and adjust the rip fence parallel with the blade; otherwise, the chances of kickback are extreme.
- Use the splitter or riving knife for all "through cuts." The splitter or riving knife maintains the kerf in the workpiece, reducing the chance of kickback.
- Feed cuts through to completion. Anytime you stop feeding a workpiece in the middle of a cut, the chance of kickback is greatly increased.

- Keep the blade guard installed and in good working order. Only remove it when performing non-through cuts and immediately re-install the blade guard when finished with the non-through cut.
- Make multiple, shallow passes when performing a non-through cut. Making a deep non-through cut will greatly increase the chance of kickback.

Protecting Yourself From Kickback

Even if you know how to prevent kickback, it may still happen. Here are some tips to protect yourself if kickback DOES occur:

- Stand to the side of the blade during every cut. If a kickback does occur, the thrown workpiece usually travels directly in front of the blade.
- Wear safety glasses or a face shield. In the event of a kickback, your eyes and face are the most vulnerable part of your body.
- Never, for any reason, place your hand behind the blade. Should kickback occur, your hand will be pulled into the blade.
- Use a push stick to keep your hands farther away from the moving blade. If a kickback occurs, the push stick will most likely take the damage that your hand would have received.
- Use featherboards or anti-kickback devices to prevent or slow down kickback.



Glossary of Terms

The following is a list of common definitions, terms and phrases used throughout this manual as they relate to this table saw and woodworking in general. Become familiar with these terms for assembling, adjusting or operating this machine. Your safety is **VERY** important to us at Grizzly!

Arbor: A metal shaft extending from the drive mechanism that is the mounting location for the saw blade.

Bevel Edge Cut: Tilting the arbor and saw blade to an angle between 0° and 45° to cut a beveled edge onto a workpiece.

Blade Guard: Metal or plastic safety device that mounts over the saw blade. Its function is to prevent the operator from coming into contact with the saw blade.

Crosscut: Cutting operation in which the cross-cut fence is used to cut across the shortest width of the workpiece.

Dado Blade: Blade or set of blades that are used to cut grooves and rabbets.

Dado Cut: Cutting operation that uses a dado blade to cut a flat bottomed groove into the face of the workpiece.

Featherboard: Safety device used to keep the workpiece against the rip fence and against the table surface.

Kerf: The resulting cut or gap in the workpiece after the saw blade passes through during a cutting operation.

Kickback: An event in which the workpiece is propelled back towards the operator at a high rate of speed.

Parallel: Being an equal distance apart at every point along two given lines or planes (i.e. the rip fence face is parallel to the face of the saw blade).

Non-Through Cut: A sawing operation that requires the removal of the blade guard and splitter or the riving knife. Dado and rabbet cuts are considered Non-Through Cuts because the blade does not protrude above the top face of the wood stock. Deep Non-Through Cuts must be made with multiple, light passes to reduce chance of kickback. Always remember to re-install the blade guard and riving knife after performing a non-through cut.

Perpendicular: Lines or planes that intersect and form right angles (i.e. the blade is perpendicular to the table surface).

Push Stick: Safety device used to push the workpiece through a cutting operation. Used most often when rip cutting thin workpieces.

Rabbet: Cutting operation that creates an L-shaped channel along the edge of the workpiece.

Riving Knife or Splitter: Metal plate located behind the blade. It maintains the kerf opening in the wood when performing a cutting operation.

Straightedge: A tool used to check the flatness, parallelism, or consistency of a surface(s).

Through Cut: A sawing operation in which the workpiece is completely sawn through.

Rip Cut: Cutting operation in which the rip fence is used to cut across the widest width of the workpiece.



SECTION 2: CIRCUIT REQUIREMENTS

Operation

!WARNING

Serious personal injury could occur if you connect the machine to power before completing the setup process. **DO NOT** connect the machine to the power until instructed later in this manual.

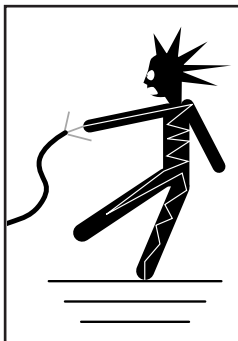

!WARNING

Electrocution or fire could result if machine is not grounded and installed in compliance with electrical codes. Compliance **MUST** be verified by a qualified electrician!

Full Load Amperage Draw

G0605X @ 220V	23 Amps
G0606X @ 220V	19 Amps
G0606X @ 440V*	10 Amps

Circuit Requirements

You **MUST** connect your machine to a grounded circuit that is rated for the amperage given below. Never replace a circuit breaker on an existing circuit with one of higher amperage without consulting a qualified electrician to ensure compliance with wiring codes. **If you are unsure about the wiring codes in your area or you plan to connect your machine to a shared circuit, consult a qualified electrician.**

G0605X @ 220V	30 Amps
G0605X @ 220V	30 Amps
G0606X @ 440V	15 Amps

Power Connection Device

The power connection device depends on the type of installed or planned service. We recommend using one of the devices shown in **Figure 2**, depending on the voltage being used.

G0605X @220V Single-Phase	L6-30
G0606X @220V 3-Phase	L15-30
G0606X @440V 3-Phs.....	Hardwired Locking Disconnect Switch

For 440V connections, an electrician **MUST** hardwire the machine (using a metal conduit setup) directly to a locking disconnect switch, which is directly connected to the power source.

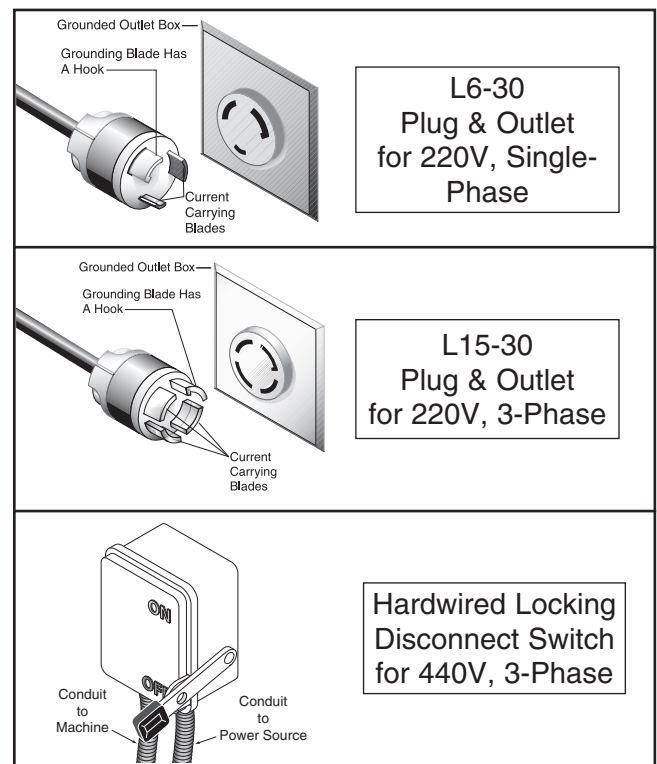

Figure 2. Recommended connection types.



Extension Cords (220V Only)

Using extension cords may reduce the life of the motor. Instead, place the machine near a power source. If you must use an extension cord:

- Use at least a 10 gauge cord that does not exceed 50 feet in length.
- Ensure that the extension cord contains a ground wire and plug pin.

Phase Converter Precaution

The power from the manufactured leg may damage electrical components if connected to the wrong incoming power terminal on your machine. Only connect the manufactured leg to the **L3** terminal (see **Page 59** for identification).

440V Conversion

The Model G0606X can be converted for 440V operation. This conversion job consists of disconnecting the saw from the power source, rewiring the motor, switching the transformer fuse from 220V to 440V, and changing the thermal overload relay from 22 to 11 Amps. Refer to the wiring diagram and photos on **Page 60** and **58** for wiring details.

All wiring changes must be inspected by a qualified electrician before the saw is connected to the power source. If, at any time during this procedure you need help, call Grizzly Tech Support at (570) 546-9663.



SECTION 3: SET UP

Set Up Safety

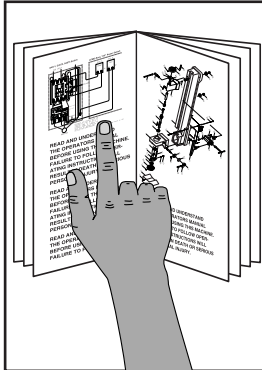

!WARNING
This machine presents serious injury hazards to untrained users. Read through this entire manual to become familiar with the controls and operations before starting the machine!



!WARNING
Wear safety glasses during the entire set up process!

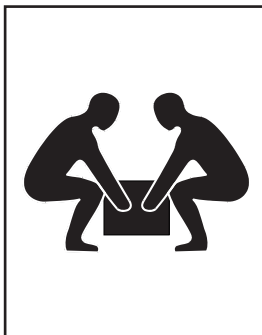

!WARNING
The Model G0605X/G0606X is a heavy machine. DO NOT over-exert yourself while unpacking or moving your machine—get assistance.

Items Needed for Set Up

The following items are needed to complete the set up process, but are not included with your machine:

Description	Qty
• Straightedge 36" (or longer)	1
• Straightedge 12" (or longer)	1
• Level	1
• Open-End Wrench 12mm	1
• Hex Wrench 3mm	1
• Safety Glasses (for each person)	1
• Dust Collection System	1
• Dust Hose 4" (length as needed)	1
• Hose Clamp 4"	1
• Assistant for Lifting Help	1
• Piece of Scrap Wood	1

Unpacking

The Model G0605X/G0606X was carefully packed when it left our warehouse. If you discover the machine is damaged after you have signed for delivery, *please immediately call Customer Service at (570) 546-9663 for advice.*

Save the containers and all packing materials for possible inspection by the carrier or its agent. *Otherwise, filing a freight claim can be difficult.*

When you are completely satisfied with the condition of your shipment, you should inventory the contents.



Machine Inventory

The following components are included with each G0605X/G0606X. After all the parts have been removed from their packaging, you should have:

Box Contents (Figures 3 & 4):	Qty
A. Table Saw Unit.....	1
B. Splitter/Guard Assembly.....	1
C. Riving Knife	1
D. Miter Gauge Handle	1
E. Miter Gauge.....	1
F. Handwheel Handles	2
G. Fence Resting Brackets	2
H. Arbor Wrenches	2
I. Arbor Extension $\frac{5}{8}$ "-18 x $1\frac{1}{4}$ "	1
J. Arbor Nut $\frac{5}{8}$ -18	1
K. Arbor Flange $\frac{5}{8}$ "	1

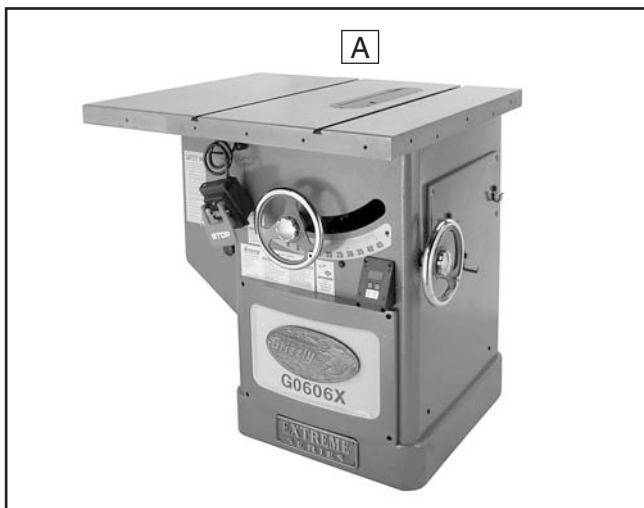

Figure 3. G0606X table saw unit.

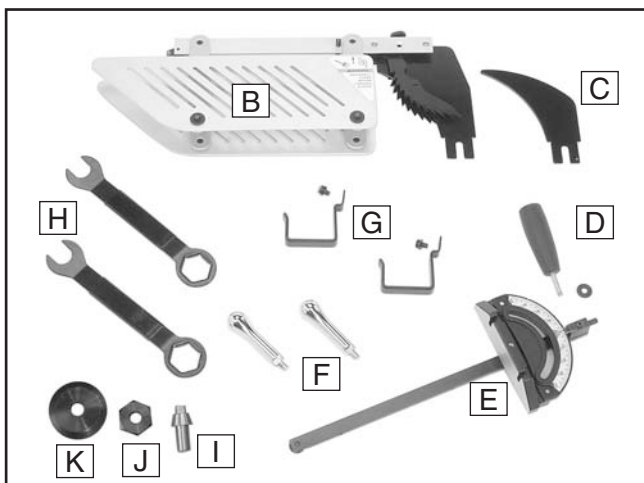

Figure 4. Main components.

Hardware and Tools (Not Shown):	Qty
• Flat Washer 8mm (Miter Gauge).....	1
• Flange Bolts M8-1.25 x 12 (Fence).....	2
• Flange Bolts M8-1.25 x 12 (Switch)	2
• Open-End Wrenches 8 x 10, 11 x 13, 14 x 17	1 Each
• Hex Wrenches 4, 5, 6mm	1 Each
• Screwdriver, Phillips/Flat.....	1
• Safety Pin (Switch).....	1
• Flat Head Screw M5-8 x 20	1

Fence Inventory

Box Contents: (Figure 5)	Qty
A. Fence	1
B. Fence Handle	1

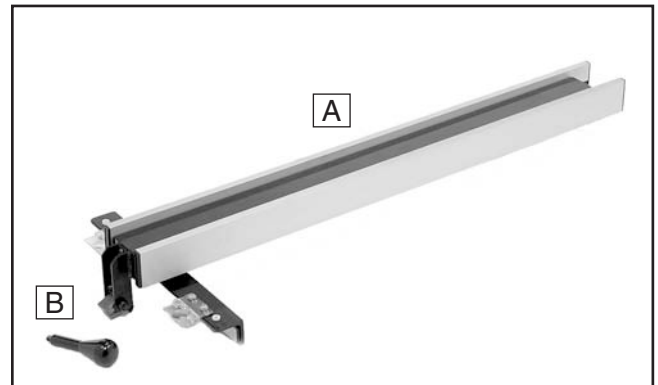

Figure 5. Fence components.

Fence Rail Inventory

Box Contents: (Figure 6)	Qty
A. Fence Tube (91 $\frac{3}{8}$ " Long).....	1
B. Front Rail (91 $\frac{3}{8}$ " Long)	1
C. Rear Rail (79" Long).....	1

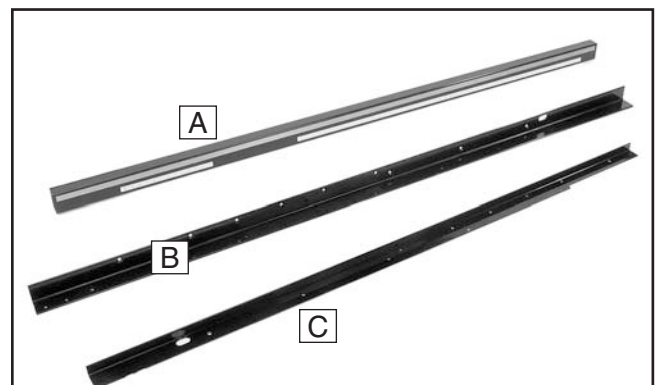

Figure 6. Fence rail components.



Extension Table Inventory

Box Contents: (Figure 7)	Qty
A. Extension Table.....	1
B. Lower Shelf	1
C. Shelf End Plate.....	1
D. Support Legs.....	2
E. Lower Shelf Brackets	2

Hardware and Tools (Not Shown):	Qty
• Cap Screws M8-1.25 x 25 (Rear Rail/Cabinet/Ext. Table)	8
• Flat Head Screws M8-1.25 x 25 (Front Rail/Cabinet/Ext. Table).....	8
• Flat Washers 8mm (Front Rail/Ext. Table/Rear Rail)	16
• Hex Nuts M8-1.25 (Front Rail/Ext. Table/ Rear Rail).....	8
• Flange Bolts M8-1.25 x 12 (Tube/ Front Rail).....	9
• Lock Washers 8mm (Rear Rail/Ext. Table).....	8
• Hex Bolts M6-1 x 12 (Brackets/Cabinet/Legs).....	4
• Hex Nuts M6-1 (Brackets/Cabinet).....	2
• Feet 3/8"-16 x 2 (Legs)	2
• Phillip Head Screws M6-1 x 12 (Ext. Table/Legs/End Plate)	12
• Flat Washers 6mm (Ext Table/Legs/End Plate)	16
• Hex Nuts 3/8-16 (Feet).....	2
• Flat Washers 10mm (Cabinet)	2
• Hex Bolts M10-1.5 x 25 (Cabinet).....	2

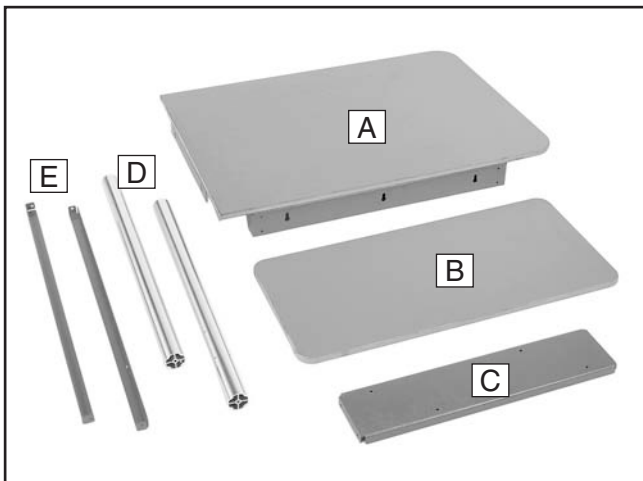

Figure 7. Extension table components.

Outfeed Table Inventory

Box Contents: (Figure 8)	Qty
A. Outfeed Table.....	1
B. Lower Shelf	1
C. Shelf End Plate.....	1
D. Support Legs.....	2
E. Lower Shelf Brackets	2

Hardware and Tools (Not Shown):	Qty
• Flange Bolts M8-1.25 x 16 (Rear Rail/Ext. Table).....	2
• Hex Nuts M8-1.25 (Rear Rail/Ext. Table) ..	2
• Hex Bolts M6-1 x 12 (Brackets/Legs/ Cabinet).....	4
• Hex Nuts M6-1 (Bracket/Legs/Cabinet)	2
• Hex Nuts 3/8-16 (Brackets/Legs/Cabinet)....	2
• Flat Washers 6mm (Brackets/Legs/Cabinet).....	16
• Phillips Head Screws M6-1 x 12 (Legs/Ext. Table/End Plate)	12
• Feet 3/8-16 x 2 (Legs).....	2
• Flange Bolts M8-1.25 x 12 (Tube/ Front Rail)	9

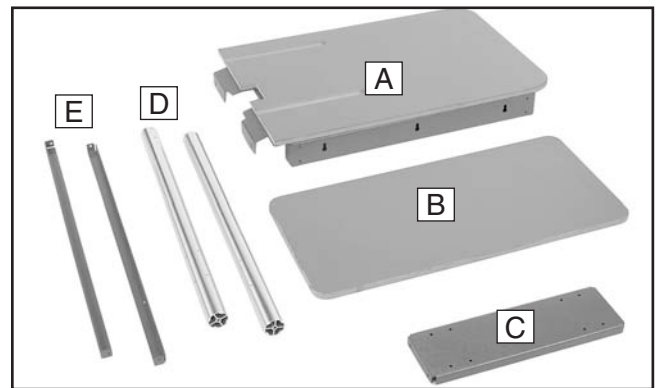

Figure 8. Outfeed table components.

In the event that any nonproprietary parts are missing (e.g. a nut or a washer), we would be glad to replace them; or for the sake of expediency, replacements can be obtained at your local hardware store.

NOTICE: Some hardware/fasteners on the inventory list may arrive pre-installed on the machine or related components. Check these locations before assuming that any items from the inventory list are missing.



Hardware Recognition Chart

USE THIS CHART TO MATCH UP HARDWARE DURING THE ASSEMBLY PROCESS.

MEASURE BOLT DIAMETER BY PLACING INSIDE CIRCLE

- #10
- 1/4"
- 5/16"
- 3/8"
- 7/16"
- 1/2"

- 4mm
- 6mm
- 8mm
- 10mm
- 12mm
- 16mm

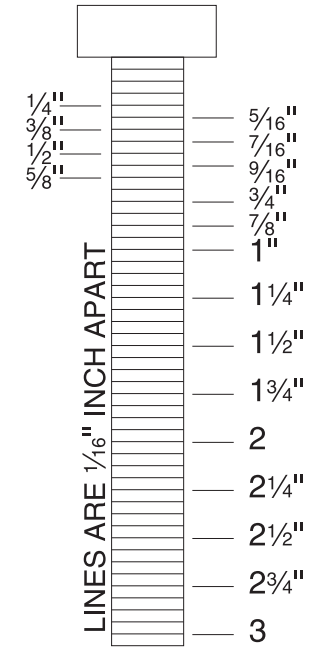
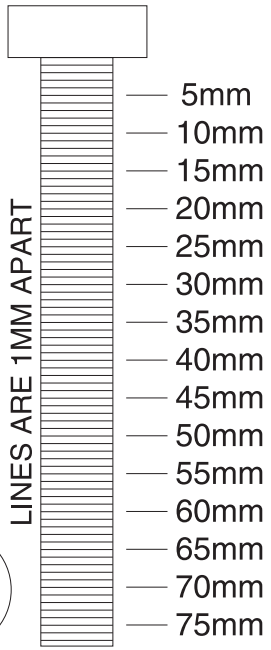
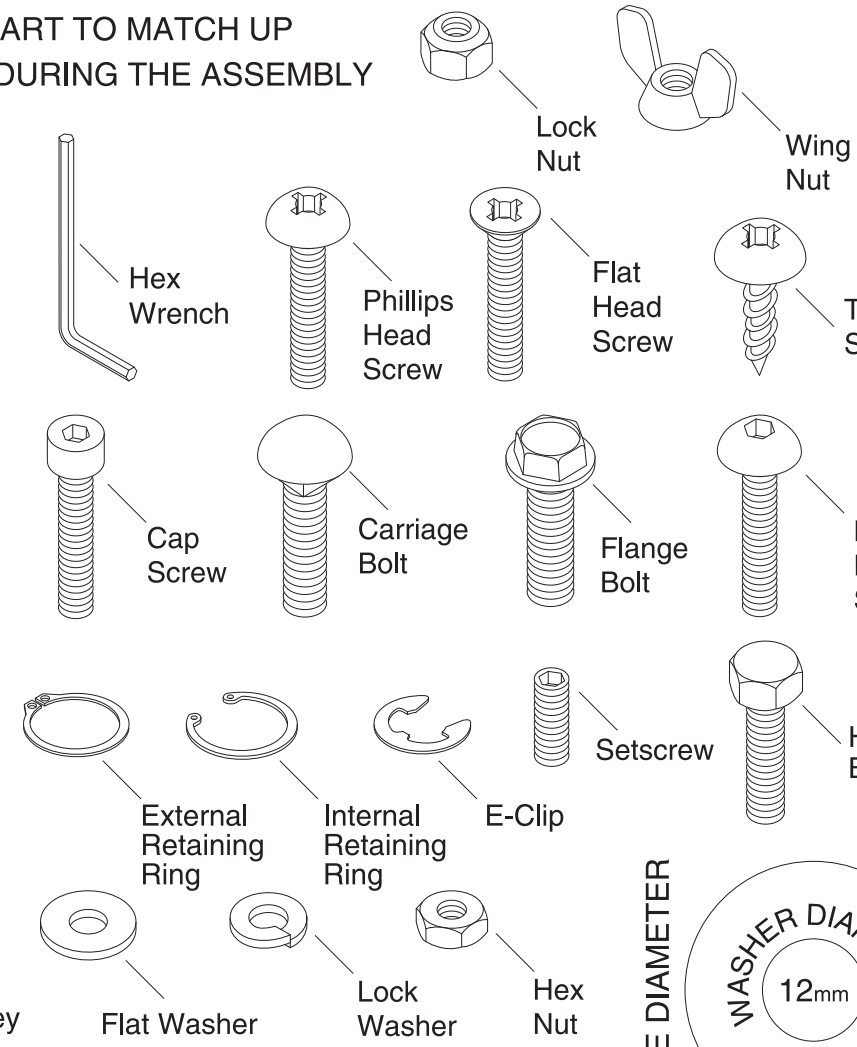

WASHERS ARE MEASURED BY THE INSIDE DIAMETER

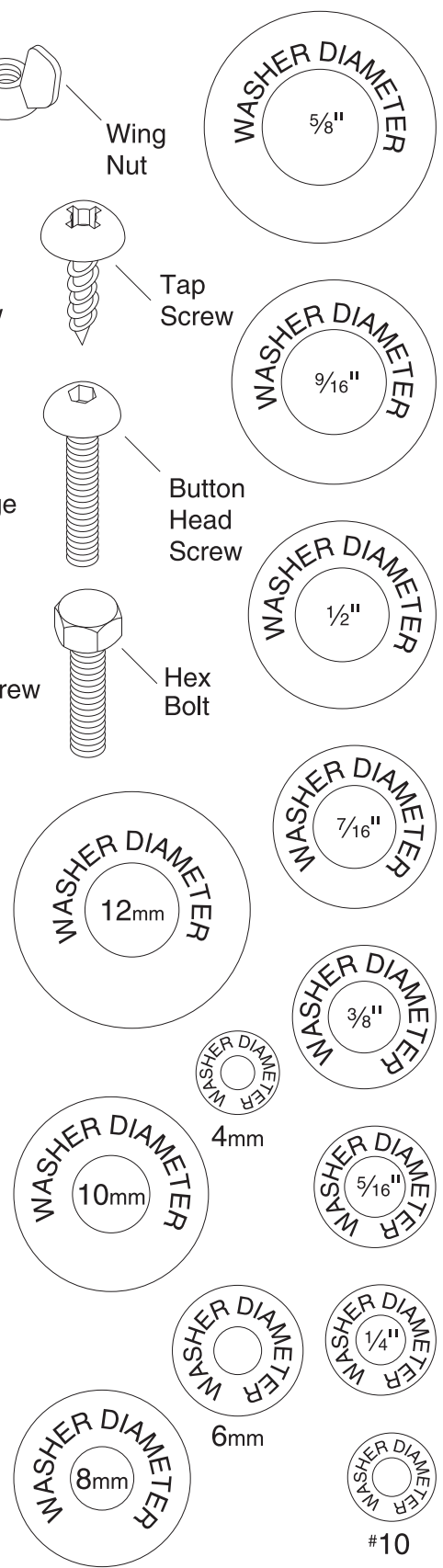

Clean Up

The unpainted surfaces are coated with a waxy oil to protect them from corrosion during shipment. Remove this protective coating with a solvent cleaner or citrus-based degreaser such as Grizzly's G7895 Degreaser. To clean thoroughly, some parts may need to be removed. **For optimum performance from your machine, make sure you clean all moving parts or sliding contact surfaces that are coated.** Avoid chlorine-based solvents, such as acetone or brake parts cleaner, as they may damage painted surfaces should they come in contact. Always follow the manufacturer's instructions when using any type of cleaning product.

	<p>⚠️ WARNING Gasoline and petroleum products have low flash points and could cause an explosion or fire if used to clean machinery. DO NOT use gasoline or petroleum products to clean the machinery.</p>
--	--

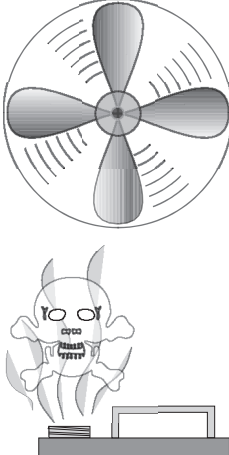
	<p>⚠️ CAUTION Many of the solvents commonly used to clean machinery can be toxic when inhaled or ingested. Lack of ventilation while using these solvents could cause serious personal health risks or fire. Take precautions from this hazard by only using cleaning solvents in a well ventilated area.</p>
---	--

Site Considerations

Floor Load

Refer to the **Machine Data Sheet** for the weight and footprint specifications of your machine. Some residential floors may require additional reinforcement to support both the machine and operator.

Placement Location

Consider existing and anticipated needs, size of material to be processed through each machine, and space for auxiliary stands, work tables or other machinery when establishing a location for your new machine. See **Figure 9** for the minimum working clearances.

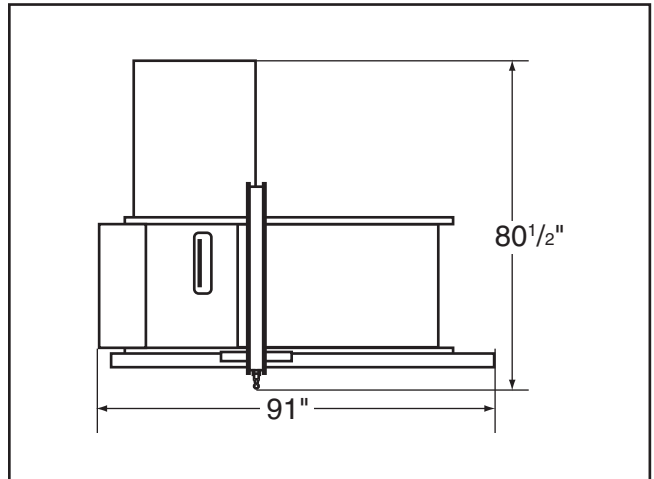

Figure 9. Minimum working clearances.

	<p>⚠️ CAUTION Children and visitors inside your shop can be seriously injured if unsupervised. Lock all entrances to the shop when you are away and DO NOT allow unsupervised children or visitors in your shop at any time!</p>
--	--



Extension Table

Components and Hardware Needed:	Qty
Table Saw Unit.....	1
Front Rail.....	1
Rear Rail.....	1
Front (Main) Extension Table.....	1
Lower Shelf.....	1
Shelf End Plate.....	1
Support Legs.....	2
Lower Shelf Brackets.....	2
Cap Screws M8-1.25 x 25.....	8
Flat Head Screws M8-1.25 x 25.....	8
Flat Washers 8mm.....	16
Hex Nuts M8-1.25.....	8
Flange Bolts M8-1.25 x 12.....	9
Lock Washers 8mm.....	8
Hex Bolts M6-1 x 12.....	4
Hex Bolts M10-1.5 x 25.....	2
Feet 3/8-16 x 2.....	2
Phillip Head Screws M6-1 x 12.....	12
Hex Nuts M6-1.....	2
Hex Nuts 3/8-16.....	2
Flat Washers 6mm.....	16
Flat Washers 10mm.....	2

To install the front and rear rails:

1. Fasten the 91³/₈" front rail onto the table saw with five flat head screws as shown in **Figure 10**.

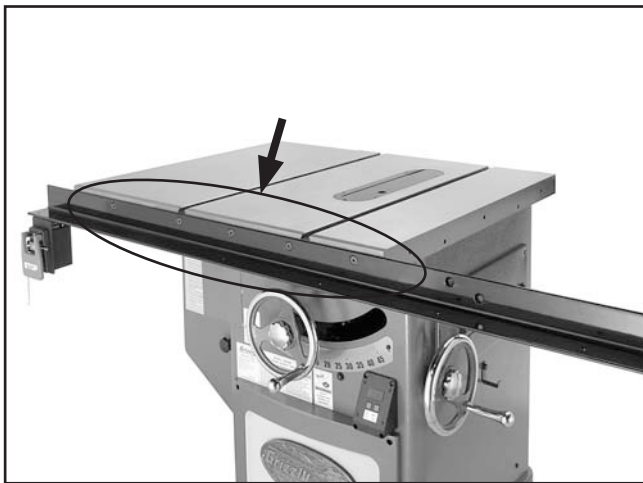

Figure 10. Front rail installed.

2. Fasten the 79" rear rail to the table with five cap screws and lock washers as shown in **Figure 11**.



Figure 11. Rear rail installed.

3. Thread two M10-1.5 x 25 hex bolts with flat washers onto the right side of the table saw cabinet as shown in **Figure 12**. Do not fully tighten the bolts.



Figure 12. Hex bolts installed.

4. With the help of an assistant, place the extension table between the rails and slide the table slots over the bolts installed in **Step 3**.



5. While an assistant holds the extension table, fasten the 91³/₈" front rail to the extension table with three flat head screws, flat washers and hex nuts (**Figure 13**). Finger tighten for now.

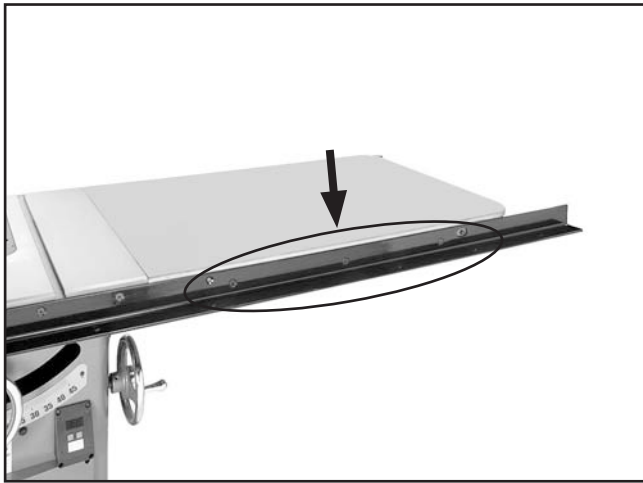

Figure 13. Front rail/table fastener locations.

6. Fasten the 79" rear rail to the extension table with three cap screws, lock washers (outside), flat washers, and hex nuts (inside), as shown in **Figure 14**. Finger tighten for now.



Figure 14. Rear rail/table fastener locations.

7. Align the table and extension table with a straightedge (**Figure 15**), then tighten the fasteners in **Figure 13** with a 5mm hex wrench and 12mm wrench.



Figure 15. Aligning main extension table.

8. Repeat the aligning procedure and tighten the fasteners in **Figure 14** with a 6mm hex wrench and 12mm wrench.
9. Using a 17mm wrench, tighten the hex bolts shown in **Figure 12**.
10. Thread a ³/₈-16 hex nut on each foot and thread the feet into the bottom of the support legs as shown in **Figure 16**.

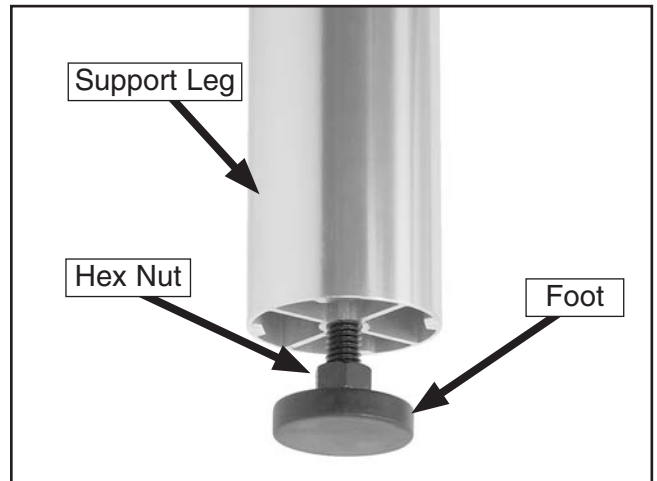

Figure 16. Foot installed on support leg.



- Fasten each support leg to the main extension table with four Phillips head screws and flat washers as shown in **Figure 17**.



Figure 17. Support leg fastened to main extension table.

- Rotate both feet until they touch the ground, and tighten the hex nuts to secure the feet.
- Fasten the shelf end plate to the legs with four Phillips head screws and flat washers as shown in **Figure 18**.



Figure 18. Installing shelf end plate on extension table legs.

- Place the shelf brackets between the cabinet and support legs, and fasten with four M6-1 x 12 hex bolts, four flat washers and two hex nuts (on the outside) as shown in **Figure 19**.

Note: The flange on the shelf bracket must point up to ensure proper installation.

- Place the lower shelf on the brackets.

Model G0605X/G0606X (Mfg. since 11/06)

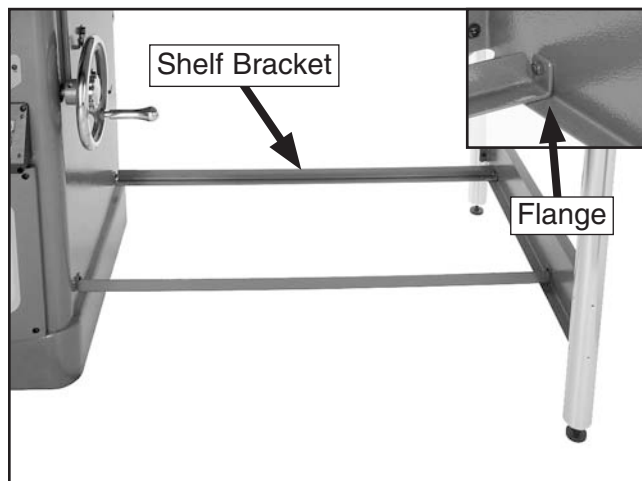

Figure 19. Shelf brackets installed.

Outfeed Table

Components and Hardware Needed:	Qty
Outfeed Table.....	1
Lower Shelf.....	1
Shelf End Plate.....	1
Support Legs.....	2
Lower Shelf Brackets.....	2
Fence Tube.....	1
Flange Bolts M8-1.25 x 16.....	2
Hex Bolts M6-1 x 12.....	4
Phillips Head Screws M6-1 x 12.....	12
Feet 3/8-16 x 2.....	2
Hex Nuts M6-1.....	2
Hex Nuts M8-1.25.....	2
Hex Nuts 3/8-16.....	2
Flat Washers 6mm.....	16
Flange Bolts M8-1.25 x 12.....	9

To install the outfeed table:

- Turn the outfeed table upside down and place it on a level surface.
- Install the feet, support legs, and shelf end plate in the same manner as described in **Extension Table** instructions.



- Place the extension table assembly upright with the feet on the ground, align the slots in the extension table bracket with the rear rail mounting holes, then fasten the table to the rail with two M8-1.25 x 16 flange bolts and hex nuts shown in **Figure 20**.

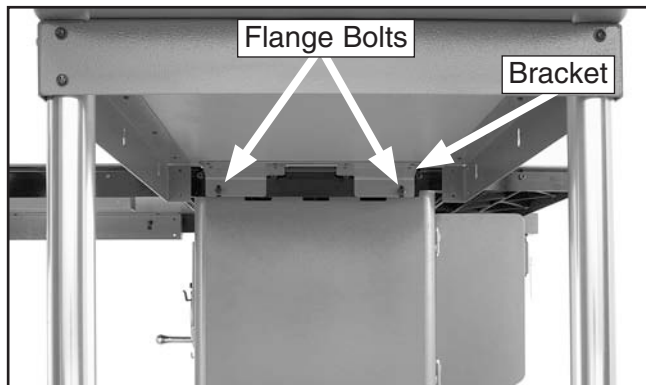

Figure 20. Outfeed table fastened to rear rail.

- Secure the lower shelf brackets to the support legs and cabinet with four M6-1 x 12 hex bolts, four flat washers and two hex nuts.
- Install the lower shelf on the brackets.
- Place the 91³/₈" fence tube over the 91³/₈" front rail and secure with nine M8-1.25 x 12 flange bolts as shown in **Figure 21**.

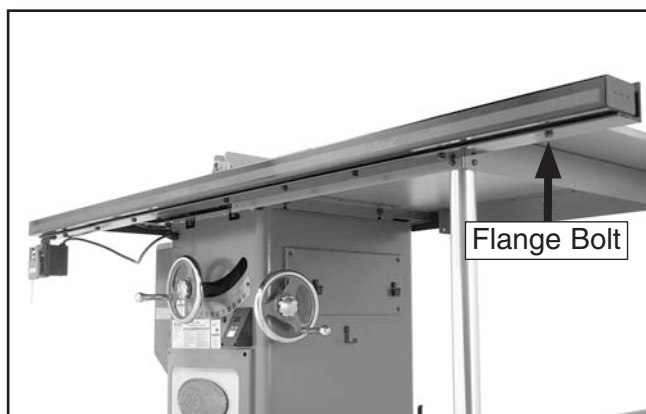

Figure 21. Fence tube mounted to front fence rail.

Saw Blade

!WARNING

The saw blade is extremely sharp. Use extra care when handling the blade or working near it. Serious injury is possible.

Review this section, even if your saw blade came pre-installed.

To install the blade:

- DISCONNECT THE SAW FROM POWER!
- Remove the table insert, blade guard, and splitter—if previously installed.
- Use the arbor wrenches to loosen and remove the arbor nut, flange, and blade.

Note: The arbor nut has right hand threads; turn it counterclockwise to loosen.
- Slide the blade over the arbor with the teeth facing the front of the saw, as shown in **Figure 22**.

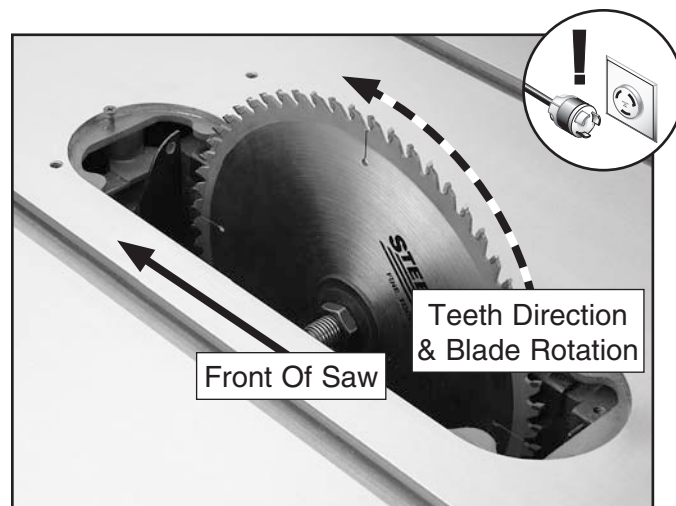

Figure 22. Correct blade direction.

- Re-install the arbor flange and the arbor nut, and tighten them against the blade with the wrench included with the saw. DO NOT over-tighten.



Arbor

A 1" or 5/8" arbor can be installed on the table saw, depending upon the arbor size of the blade you want to install.

To change the arbor:

1. DISCONNECT THE SAW FROM POWER!
2. Remove the table insert, blade guard and splitter or riving knife, arbor nut, arbor flange, and blade.
3. Raise the arbor all the way up.
4. Hold the arbor shaft with the arbor wrench and, using a 5mm hex wrench, remove the cap screw from the end of the arbor, as shown in **Figure 23**.

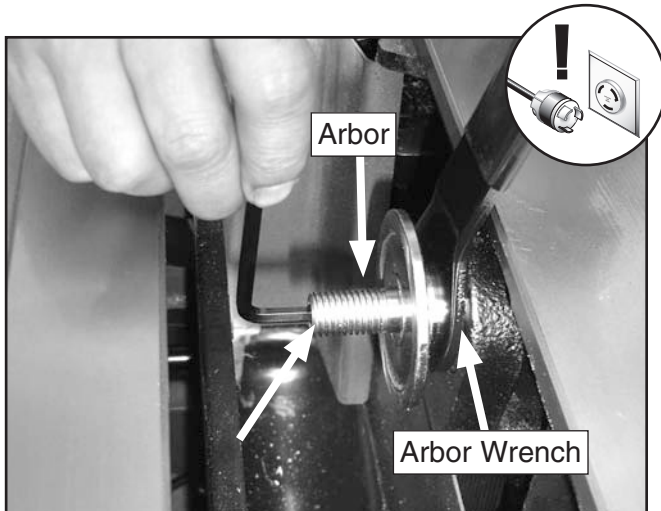

Figure 23. Removing arbor.

Note: Gently tap the arbor with a rubber mallet to unseat it if it is hard to remove.

5. Slide the arbor out of the arbor shaft and reinstall the new arbor in the same manner that the old one was removed. Make sure the new arbor is securely tightened in the arbor shaft before reinstalling the blade.

Table Insert

You MUST install the table insert before operating the table saw.

Components and Hardware Needed:	Qty
Table Insert	1
Flat Head Screw M5-.8 x 20	1

To install and adjust the table insert:

1. DISCONNECT THE SAW FROM POWER!
2. Place the table insert into the table and tighten the screw shown in **Figure 24**.

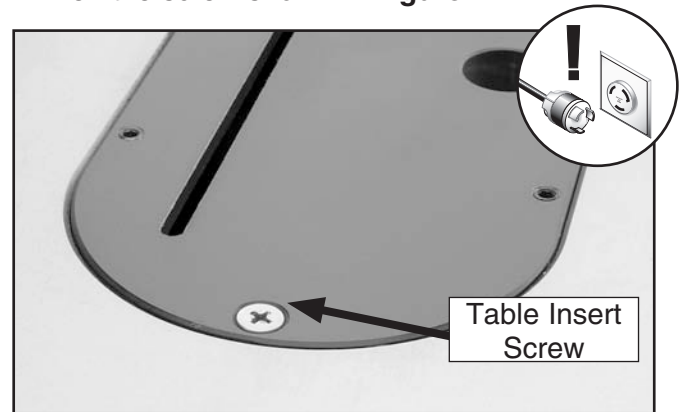

Figure 24. Table insert screw.

Note: Do not overtighten the table insert screw. If you have questions, contact Technical Support.

3. Place a straightedge across the table and the table insert.
4. Use a 3mm hex wrench and straightedge to adjust the table insert flush with the table as shown in **Figure 25**.

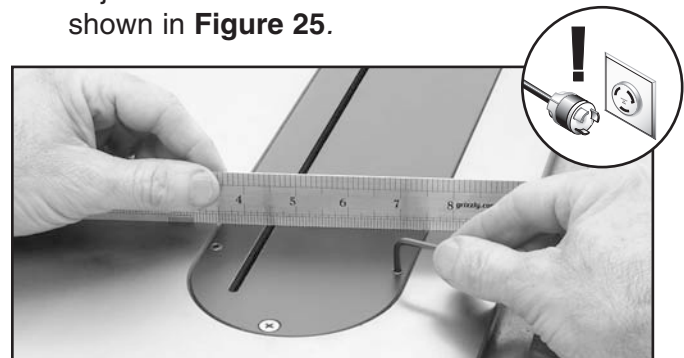

Figure 25. Adjusting the table insert.

The table insert must be flush with the table top or the workpiece will hit the edge of the table insert at the beginning of the cut.



Blade Guard and Splitter

You **MUST** install the blade guard and splitter before operating the table saw.

Components and Hardware Needed:	Qty
Splitter	1
Blade Guard	1

To install the blade guard:

1. DISCONNECT THE SAW FROM POWER!
2. Raise the blade up all the way, unscrew the screw on the table insert, and remove the insert.
3. Using an arbor wrench, loosen the hex bolt shown in **Figure 26**.

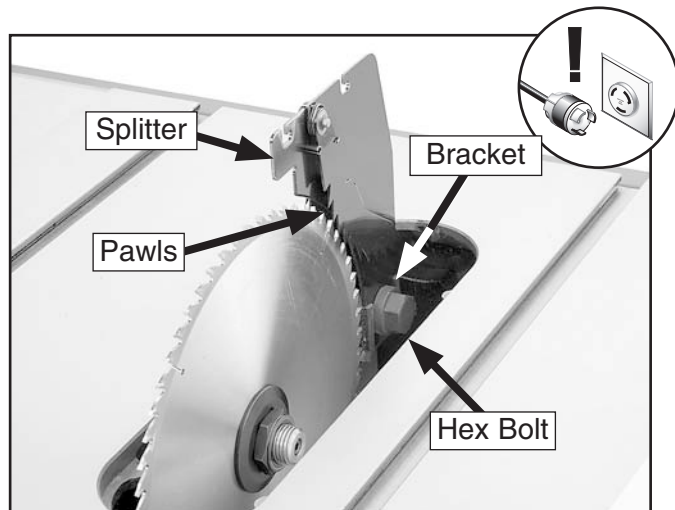

Figure 26. Splitter installed.

4. While lifting up on the splitter pawls, insert the splitter into the bracket slot, and tighten the hex bolt to lock the splitter.
5. Reinstall the table insert and secure it with the screw removed in **Step 2**.

6. Slide the bracket screws shown in **Figure 27** into the notches on the splitter, push the guard toward the back of the table, and tighten the lock knob (**Figure 28**). If you have difficulty sliding the blade guard bracket screws (**Figure 27**) into the notches on the splitter, loosen the bracket screws just enough so the guard fits on the splitter.

Note: Make sure the clear plastic flap is pushed toward the inside of the guard.

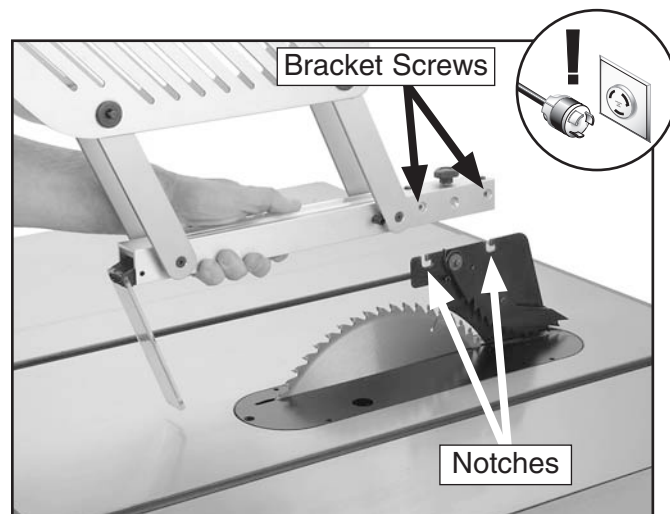

Figure 27. Installing blade guard on splitter.

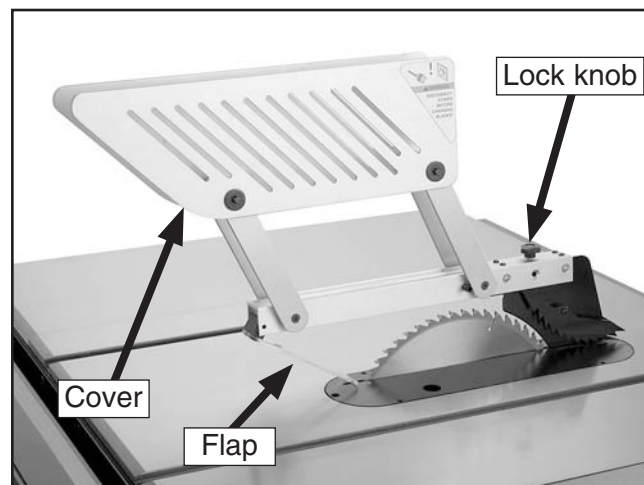

Figure 28. Blade guard installed.

7. Swing the covers down to guard the blade.



Riving Knife

Review this section, even if your saw riving knife came pre-installed. You must install the riving knife or the splitter and blade guard before operating the table saw.

Components and Hardware Needed:	Qty
Riving Knife	1

To install the riving knife:

1. Remove the table insert, blade guard, and splitter—if previously installed.
2. Loosen the hex bolt (**Figure 29**), insert the riving knife into the bracket slot, and tighten the hex bolt to secure the riving knife.
3. Reinstall and secure the table insert.

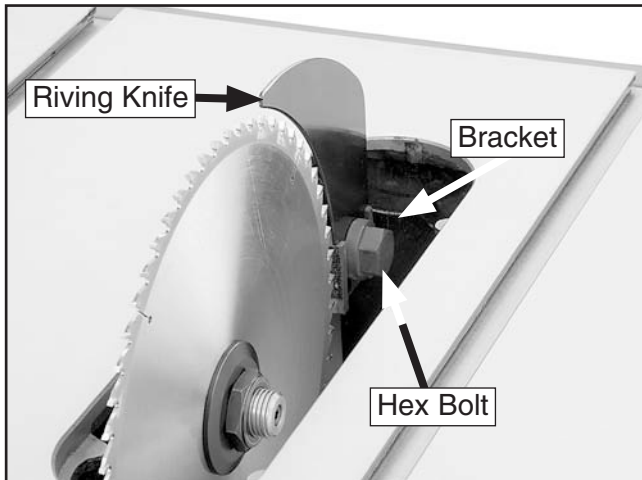

Figure 29. Riving knife installed.

On/Off Switch

Components and Hardware Needed:	Qty
Safety Pin	1
Flange Bolts M8-1.25 x 25.....	2

To install the switch:

1. Fasten the switch to the left end of the front rail with two flange bolts, and install the anti-start safety pin as shown in **Figure 30**.

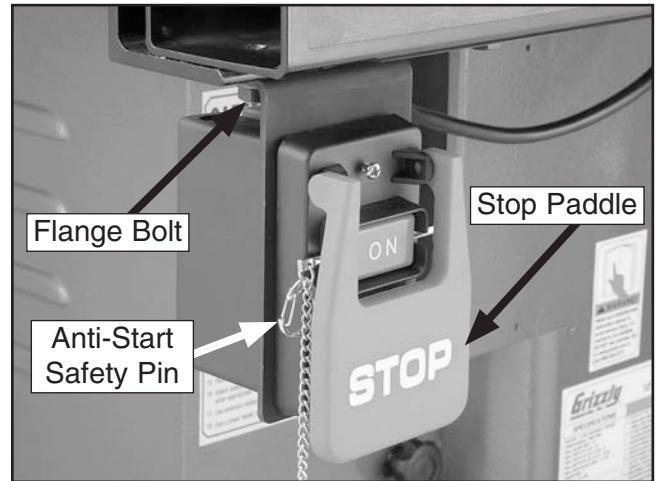

Figure 30. Switch installed.

Miter Gauge

Components and Hardware Needed:	Qty
Miter Gauge.....	1
Miter Gauge Handle	1
Flat Washer 8mm	1

To install the miter gauge:

1. Install the miter gauge handle and 8mm flat washer onto the miter gauge as shown in **Figure 31**.

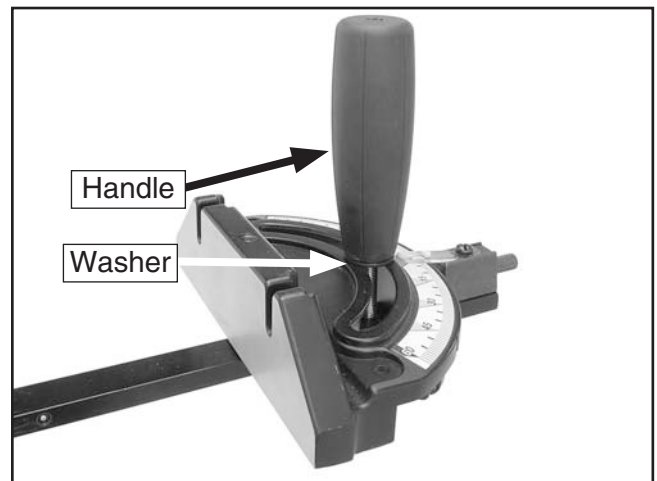

Figure 31. Miter gauge installed.

2. Slide the miter gauge into the miter gauge slot to the left of the blade; or store it temporarily on the brackets near the blade angle handwheel.



Fence Components

Components and Hardware Needed:	Qty
Fence Knob	1
Fence Resting Brackets	2
Flange Bolts M8-1.25 x 12.....	2

To install the fence knobs, fence, and fence resting brackets:

1. Install the fence knob as shown in **Figure 32**.



Figure 32. Fence knob installed.

2. Install the fence onto the table to the right of the blade.
3. Check for fence parallelism and adjust if needed. See **Adjusting Fence** on **Page 54**.
4. Install the fence resting brackets (**Figure 33**) onto the back of the cabinet with the two flange bolts.

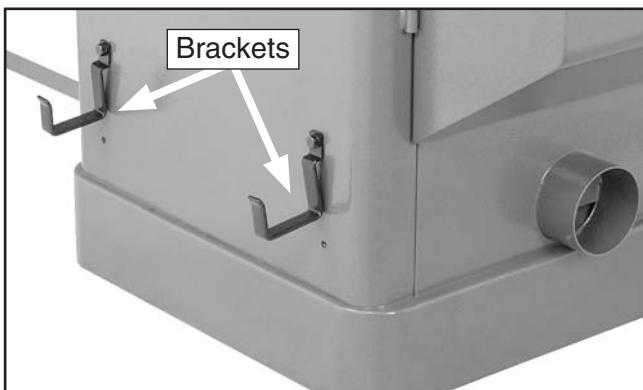

Figure 33. Fence resting brackets installed.

Dust Collection

CAUTION

DO NOT operate the Model G0605X/G0606X without an adequate dust collection system. This saw creates substantial amounts of wood dust while operating. Failure to use a dust collection system can result in short and long-term respiratory illness.

Components and Hardware Needed:	Qty
4" Dust Hose (not included)	1
4" Hose Clamp (not included)	2
Dust Collection System (not included)	1

Recommended CFM at Dust Port: 400 CFM
Do not confuse this CFM recommendation with the rating of the dust collector. To determine the CFM at the dust port, you must take into account many variables, including the CFM rating of the dust collector, the length of hose between the dust collector and the machine, the amount of branches or wyes, and the amount of other open lines throughout the system. Explaining this calculation is beyond the scope of this manual. If you are unsure of your system, consult an expert or purchase a good dust collection "how-to" book.

To connect a dust collection hose:

1. Fit the 4" dust hose over the dust port, as shown in **Figure 34**, and secure in place with a hose clamp.
2. Tug the hose to make sure it does not come off. **Note:** A tight fit is necessary for proper performance.



Figure 34. Dust hose attached to dust port.



Recommended Adjustments

The adjustments listed below have been performed at the factory and no further setup is required to operate the machine.

However, because of the many variables involved with shipping, we recommend checking the following adjustments to ensure the best possible results from your new machine:

Recommended adjustment checklist:

- Blade Tilt Stops on **Page 50**
- Miter Slot to Blade Parallelism on **Page 52**

Test Run

Once the assembly is complete, test run your machine to make sure it runs properly for regular operations.

The test run consists of verifying the following: 1) The motor powers up and runs correctly, and 2) the safety disabling mechanism on the switch works correctly, and 3) to check for unusual noises or vibration.

If, during the test run, you cannot easily locate the source of an unusual noise or vibration, stop using the machine immediately, then review the **Troubleshooting** on **Page 46**.

If you still cannot remedy a problem, contact our Tech Support at (570) 546-9663 for assistance.

To test run the machine:

1. Read this manual and make sure you understand **SECTION 1: SAFETY** on **Page 7**.
2. Review **CIRCUIT REQUIREMENTS** on **Page 12**, and make any necessary changes.
3. Make sure the blade guard and splitter (or riving knife) are installed and correctly adjusted.

4. Remove all tools and foreign objects from the machine.
5. Connect the tablesaw to the power source.
6. Put on safety glasses and hearing protection, and make sure any bystanders are wearing safety glasses, hearing protection, and are out of the way.
7. Make sure the safety pin is not installed.
8. Keep a finger on the STOP paddle (**Figure 30**) at all times during the test run.
9. Verify that the machine is operating correctly by pressing the ON button.

—If the saw is operating normally, press the STOP paddle. This should stop the saw.

—If any problems occur, immediately press the STOP paddle and **DISCONNECT THE SAW FROM THE POWER SOURCE**. Turn to **Troubleshooting** on **Page 46** and correct the problem before starting the table saw again.

—If you cannot easily locate the source of an unusual noise or vibration by yourself, please contact Technical Support at (570) 546-9663.

10. Lift the paddle switch and insert the safety pin through the ON button.
11. Press the ON button.
 - If the saw does not start, the safety disabling feature is working correctly.
 - If the saw starts, immediately press the OFF button and **DISCONNECT THE SAW FROM THE POWER SOURCE**. The safety disabling feature is not working correctly. Please contact our Technical Support at (570) 546-9663 immediately.



12. Model G0606X only: Verify that the power is not connected out of phase by starting/stopping the table saw and determining if the motor turns in the correct direction, using the criteria below:

—If the blade turns clockwise (as standing in front of the table saw), it is turning in the correct direction.

—If the blade turns counterclockwise, toward the back of the saw, it is turning in the wrong direction.

Stop the table saw, shut **OFF** the power source, swap any two of the three power wires—L1, L2, or L3—that connect to the saw. If using a phase converter for 220V 3-phase operation, **ONLY** swap L1 and L2.

13. Verify that the arbor nut is secure. The saw is now ready to operate.

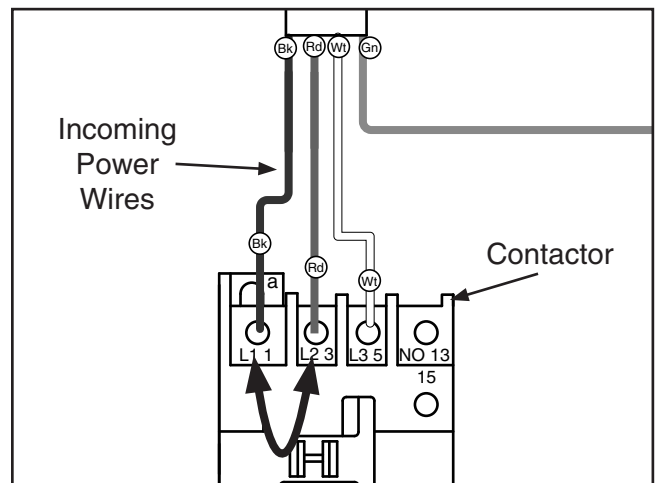

Figure 35. Example of switching incoming power wires.



SECTION 4: OPERATIONS

Operation Safety

!WARNING

Damage to your eyes, lungs, and ears could result from using this machine without proper protective gear. Always wear safety glasses, a respirator, and hearing protection when operating this machine.

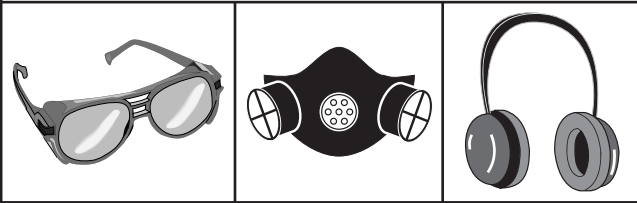

!WARNING

Loose hair and clothing can get caught in machinery and cause serious personal injury. Keep loose clothing and long hair away from machinery.

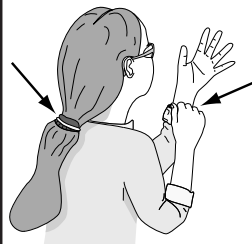

!WARNING

Keep the blade guard in the down position at all times. Failure to do this could result in serious personal injury or death.

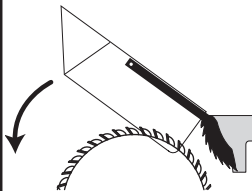

NOTICE

If you have never used this type of machine or equipment before, WE STRONGLY RECOMMEND that you read books, trade magazines, or get formal training before beginning any projects. Regardless of the content in this section, Grizzly Industrial will not be held liable for accidents caused by lack of training.

Basic Controls

The basic controls for the table saw are shown in **Figure 36**. Setting up for a typical operation consists of the following four steps:

1. Make sure the blade tilt is correct. If it needs to be adjusted, loosen the blade tilt lock, turn the blade tilt handwheel, and tighten the lock.
2. Set the blade height approximately $\frac{1}{4}$ " higher than the workpiece thickness by turning the blade height handwheel, then lock the blade height in place by tightening the blade height lock.
3. Adjust the fence to the desired width of cut, then lock it in place by firmly pushing the fence lock down until it stops.

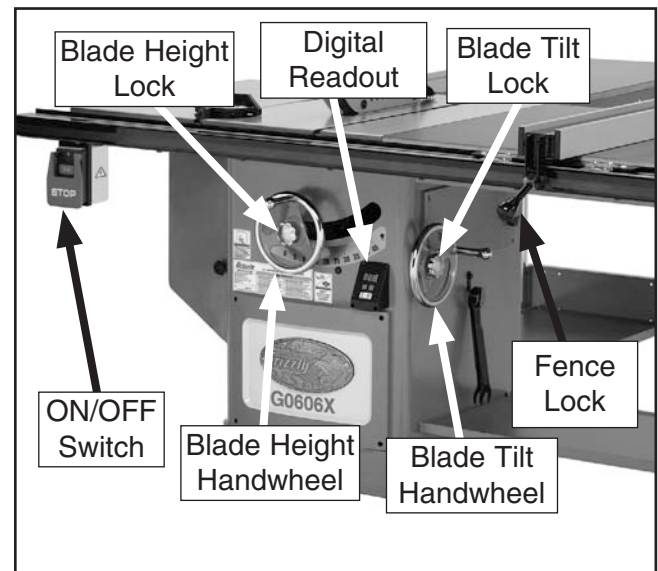

Figure 36. Basic table saw controls.

4. The digital readout displays the current blade angle when the handwheel is moved and power is connected to the table saw. See **Page 51** for setting the digital readout.



Disabling On/Off Switch

To disable the saw and prevent accidental startup, insert the safety pin through the holes in the ON button, and insert the end of the chain into the pin as shown in **Figure 37**.



Figure 37. Disabling switch.

Blade Selection

Ripping blade features:

- Best for cutting with the grain of the workpiece.
- 20-40 teeth.
- Flat-top ground tooth profile.
- Large gullets for large chip removal.

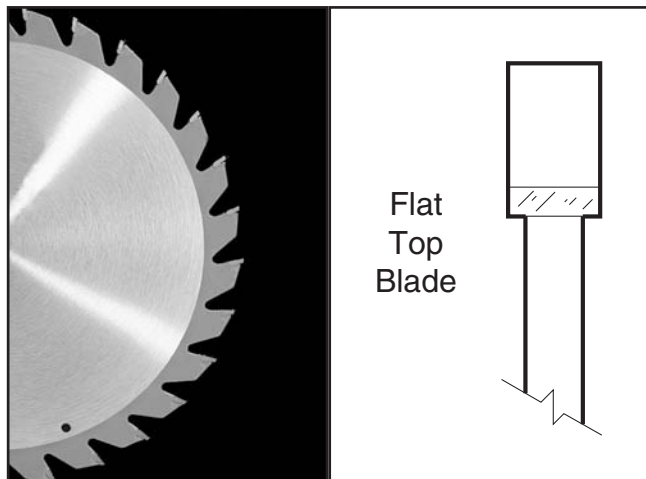

Figure 38. Ripping blade.

Crosscut blade features:

- Best for cutting across the grain of the workpiece.
- 60-80 teeth.
- Alternate top bevel tooth profile.
- Small hook angle and a shallow gullet.

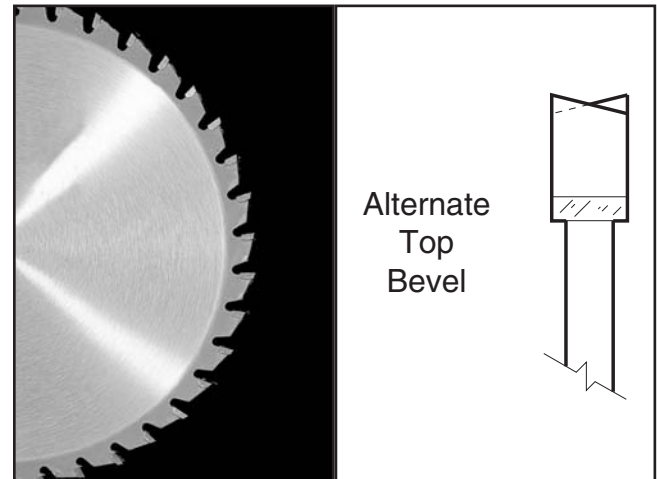

Figure 39. Crosscutting blade.

Combination blade features:

- Adequate for cutting both with and across the grain.
- 40-50 teeth.
- Alternate top bevel and flat, or alternate top bevel and raker tooth profile.
- Teeth are arranged in groups of five.
- Gullets are small and shallow within the groups of five teeth, similar to a cross-cut blade; then large and deep between each group of five, like a ripping blade.

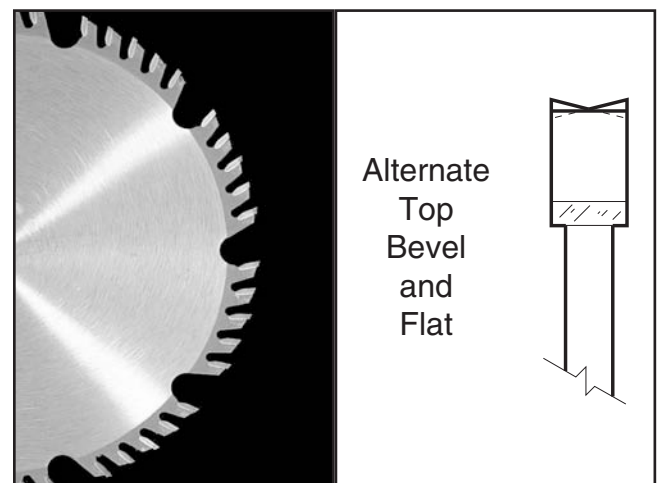

Figure 40. Combination blade.



Laminate blade features:

- Best for cutting plywood or veneer.
- 40-80 teeth.
- Triple chip tooth profile.
- Very shallow gullet.

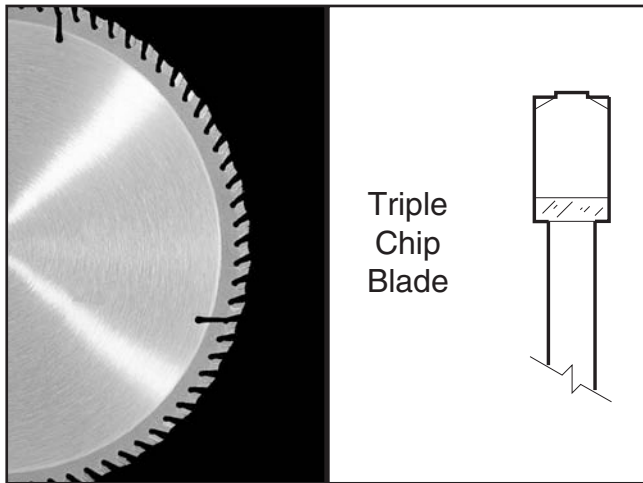

Figure 41. Laminate blade.

Dado Blades:

There are two types of dado blades: stacked and wobble.

- **Stacked Dado Blade:** These dedicated dado cutting blade sets consist of up to 8 individual blades. Multiple cutters are "stacked" between two outside blades. The width of the dado is determined by the combination of cutters that are "stacked" together. The dado is cut in a single pass leaving a smooth and square channel in the face of the workpiece. Stacked dado blades are the most expensive option, but are worth considering if your projects require a lot of visible dado cuts. A stacked dado blade is shown in **Figure 42**.

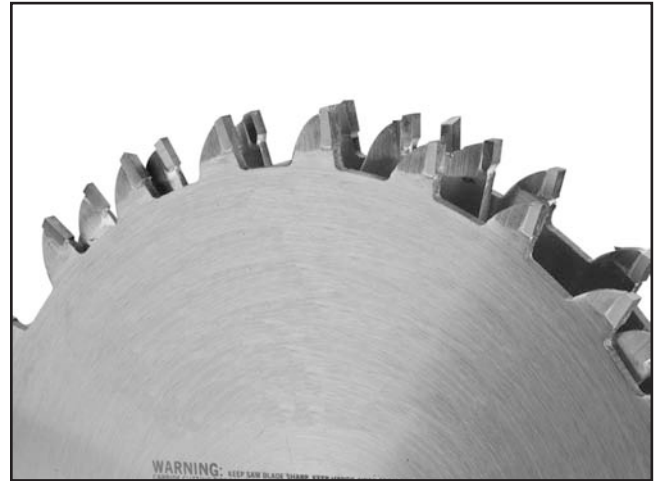

Figure 42. Stacked dado blade.

- **Wobble Dado Blade:** Also a dedicated dado blade, a wobble blade usually consists of a single blade that is tilted on the arbor shaft while it is spinning. The channel is cut in the face of the workpiece as the blade passes through its pre-adjusted width of travel. Wobble blades are an inexpensive option when visibly pleasing channels are not a concern.

Note: *This section on blade selection is by no means comprehensive. Always follow the saw blade manufacturer's recommendations to ensure safe and efficient operation of your table saw.*



Workpiece Inspection

Some workpieces are not safe to cut or may require modification before they can be made safe to cut.

Before cutting, get in the habit of inspecting all workpieces for the following:

- **Foreign Objects:** Nails, staples, dirt, rocks and other foreign objects are often embedded in wood. While cutting, these objects can become dislodged and hit the operator, they can cause kickback, and they can break or chip the blade, which might then fly apart. Always visually inspect your workpiece for these items. If they can't be removed, do NOT cut the workpiece.
- **Large/Loose Knots:** Loose knots can become dislodged during the cutting operation. Large knots can cause kickback and machine damage. Choose workpieces that do not have large/loose knots or plan ahead to avoid cutting through them.
- **Wet or "Green" Stock:** Cutting wood with a moisture content over 20% causes unnecessary wear on the blades, increases the risk of kickback, and yields poor results.
- **Excessive Warping:** Workpieces with excessive cupping, bowing, or twisting are dangerous to cut because they are unstable and often unpredictable when being cut. DO NOT use workpieces with these characteristics!
- **Minor Warping:** Workpieces with slight cupping can be safely supported if the cupped side is facing the table or the fence. On the contrary, a workpiece supported on the bowed side will rock during a cut and could cause kickback or severe injury.

Non-Through & Through Cuts

Non-Through Cuts

A non-through cut is a sawing operation where the blade does not protrude above the top face of the wood stock. Since non-through cuts require the removal of the blade guard and splitter, the riving knife must be installed. Dado cuts, rabbet cuts, and resawing operations are non-through cuts that can be performed with this table saw.

Non-through cuts have a higher risk of injury from kickback because the splitter and blade guard must be removed. Kickback is an event in which the workpiece is propelled back towards the operator at a high rate of speed. Always remember to re-install the blade guard and splitter after performing a non-through cut.

Through Cuts

A through cut is a sawing operation in which the workpiece is completely sawn through. Ripping, crosscutting, miter cuts, and angled cuts are all through cutting operations. The blade guard and splitter or riving knife must be installed during through cuts.

Through cuts have a risk of kickback. Read, understand, and follow instructions and safety precautions for each type of cut to reduce the risk of injury.

Safety precautions and instructions for each type of cut are located on the following pages:

1. Ripping: **Page 33**
2. Crosscutting: **Page 34**
3. Miter Cuts: **Page 34**
4. Blade Tilt & Bevel Cuts: **Page 35**
5. Dado Cutting: **Page 35**
6. Rabbet Cutting: **Page 37**
7. Resawing: **Page 39**



Ripping

"Ripping" means cutting with the grain of a natural wood workpiece. In other man-made materials such as MDF or plywood, ripping simply means cutting lengthwise.

!WARNING

Serious injury can be caused by kickback. Kickback is a high-speed expulsion of stock from the tablesaw toward an operator. The operator or bystanders may be struck by flying stock, or the operator's hands can be pulled into the blade during the kickback.

To make a rip cut:

1. Review **Preventing Kickback** on **Page 10** and take the necessary precautions to prevent kickback.
2. If using natural wood, joint one long edge of the workpiece on a jointer.
3. **DISCONNECT THE SAW FROM POWER!**
4. Ensure that the blade guard and splitter or riving knife is installed.
5. Set the fence to the desired width of cut on the scale.
6. Adjust the blade height so the highest saw tooth protrudes approximately $\frac{1}{4}$ " above the workpiece.
7. Set up safety devices such as featherboards or other anti-kickback devices.
8. Rotate the blade to make sure it does not come into contact with any of the safety devices.
9. Plug the saw into the power source, turn it **ON**, and allow it to reach full speed.
10. The jointed edge of the workpiece must slide against the fence during the cutting operation.
11. Use a push stick to feed the workpiece through the saw blade, as shown in **Figure 43**, until the workpiece is completely past the saw blade.

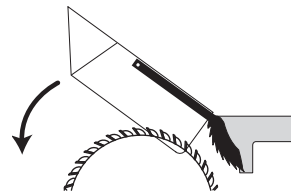

Figure 43. Typical ripping operation.

!WARNING

Turn *OFF* the saw and allow the blade to come to a complete stop before removing the cut-off piece. Failure to follow this warning could result in serious personal injury.

!WARNING



Keep the blade guard installed and in the down position. Failure to do this could result in serious personal injury or death.



Crosscutting

"Crosscutting" means cutting across the grain of a natural wood workpiece. In other man-made materials, such as MDF or plywood, crosscutting means cutting across the width of the workpiece.

To make a crosscut using the miter gauge:

1. DISCONNECT THE SAW FROM POWER!
2. Ensure that the blade guard and splitter or riving knife is installed.
3. Move the rip fence aside and position the miter gauge, adjusted to 90°, in a miter slot.
4. Adjust the blade height so the teeth protrude approximately 1/4" above the workpiece.
5. Slide the miter gauge near the blade and adjust the workpiece so the blade will cut on the waste side of the line.
6. Plug in the tablesaw, turn it **ON**, and allow it to reach full speed.
7. Hold the workpiece firmly against the face of the miter gauge (**Figure 44**) and ease it through the blade until the workpiece is completely past the saw blade.

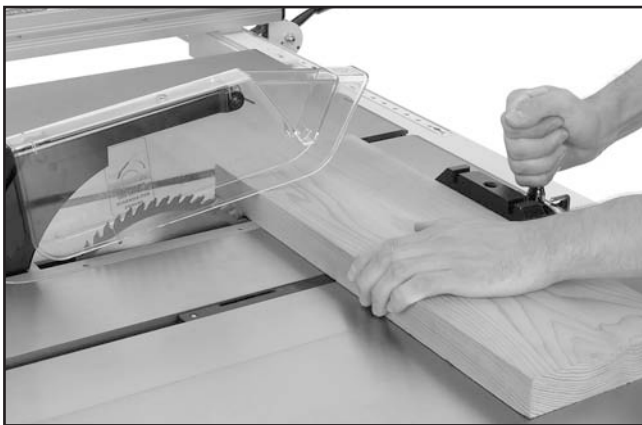

Figure 44. Typical crosscutting operation.

!WARNING

Turn **OFF** the saw and allow the blade to come to a complete stop before removing the cut-off piece. Failure to follow this warning could result in serious personal injury

Miter Cuts

A miter is an angled crosscut. Miters are usually cut in the same manner as crosscuts, using the miter gauge and a predetermined mark on the workpiece.

To perform a miter cut:

1. DISCONNECT THE SAW FROM POWER!
2. Ensure that the blade guard and splitter or riving knife is installed.
3. Determine the angle of your cut. If the angle needs to be very precise, use a protractor to set the miter gauge to the blade.
4. Place the face of the miter gauge against the edge of the workpiece and place the bar across the face of the workpiece. Use the bar as a guide to mark your cut as shown in **Figure 45**.



Figure 45. Example of marking miter line.

5. Place the miter gauge back into the slot and hold the workpiece firm against the miter gauge body. Slide the miter gauge near the blade and adjust the workpiece so the blade will cut on the waste side of the line.
6. Proceed to make the cut in the same manner as described in the **Crosscutting** instructions.



Blade Tilt/Bevel Cuts

When the blade tilt stop bolts are properly adjusted (**Page 50**), the blade tilt handwheel allows the operator to tilt the blade to the left, anywhere between 0° and 45°. This is used most often when cutting bevels, compound miters or chamfers. **Figure 46** shows an example of the blade when tilted to 45°.

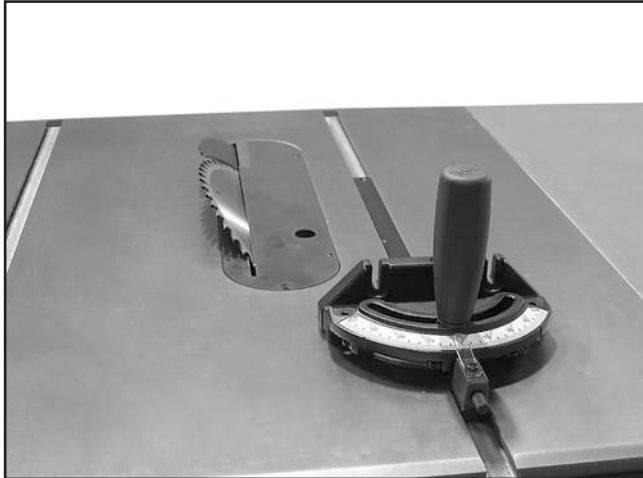

Figure 46. Blade tilted to 45° for bevel cutting on a typical table saw.

Dado Cutting

Commonly used in furniture joinery, a dado is a straight channel cut in the face of the workpiece. Dadoes can be cut using either a dedicated dado blade or a standard saw blade. The optional dado insert, Model H9910, (see **Page 43**) must be installed during dado cutting.

The table saw motor is pushed to its limits when making a dado cut. If the motor starts to bog down, slow down your feed rate and make multiple shallow passes.

!WARNING

Dado operations require proper procedures to avoid serious injury. Extra care must be taken to prevent kickback when using dado blades. Any movement of the workpiece away from the fence will cause kickback. Be certain that stock is flat and straight. Failure to follow these warnings could result in serious personal injury.

!WARNING

DO NOT make a through-cut with a dado blade. Dado blades are not designed for through cuts. Failure to follow this warning could result in serious personal injury.

To use a stacked or wobble dado blade:

1. DISCONNECT THE SAW FROM POWER!
2. Remove the table insert, the blade guard and splitter, and the saw blade.
3. Install the riving knife.
4. Attach and adjust the dado blade system according to the dado blade manufacturer's instructions.
5. Install the optional dado insert.



6. Raise the dado blade up to the desired depth of cut (depth of dado channel desired). When cutting deep dados, take more than one pass to reduce the risk of kickback.

⚠ WARNING

The danger of kickback increases relative to the depth and width of a cut. Reduce the risk of kickback by making multiple passes to achieve the desired depth of cut. Failure to follow these warnings could result in serious personal injury.

7. Adjust the distance between the fence and the inside edge of the blade as shown in **Figure 47** to dado the length of a workpiece.

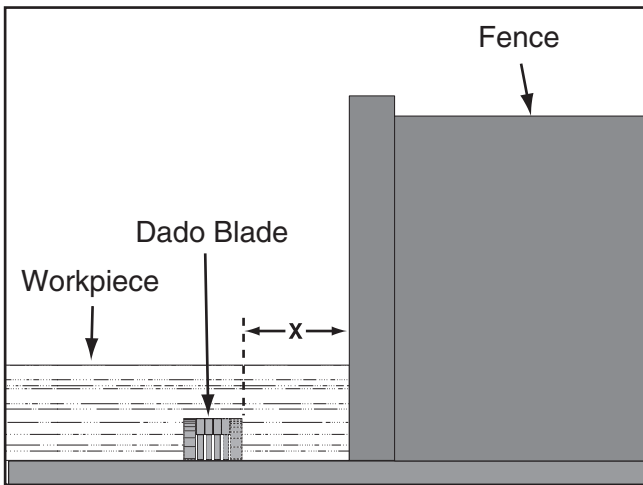

Figure 47. Stacked or wobble dado cut.

8. If dadoing across the workpiece, use the miter gauge and carefully line up the desired cut with the dado blade. **DO NOT** use the fence in combination with the miter gauge.
9. Reconnect the saw to the power source.

10. Turn the saw **ON**. The blade should run smooth, with no vibrations.
11. When the blade has reached full speed, perform a test cut with a scrap piece of wood.
12. If the cut is satisfactory, repeat the cut with the actual workpiece.

To use a standard saw blade to cut dados:

Note: Reduce motor overloading and blade wear by using a ripping blade. Ripping blades are designed to clear the sawdust quickly. See **Page 30** for more details.

1. **DISCONNECT THE SAW FROM POWER!**
2. Ensure that the riving knife and standard insert are installed.
3. Mark the width of the dado cut on the workpiece. Include marks on the edge of the workpiece so the cut path can be aligned when the workpiece is lying on the table.
4. Raise the blade up to the desired depth of cut (depth of dado channel desired). When cutting deep dados, take more than one pass to reduce the risk of kickback.

⚠ WARNING

The danger of kickback increases relative to the depth and width of a cut. Reduce the risk of kickback by making multiple passes to achieve the desired depth of cut. Failure to follow these warnings could result in serious personal injury.

5. If dadoing across the workpiece, use the miter gauge to support the workpiece, and align the blade to cut one of the dado sides. **DO NOT** use the fence in combination with the miter gauge.



- If dadoing the length of a workpiece, align the blade to cut one of the dado sides as shown in **Figure 48**.

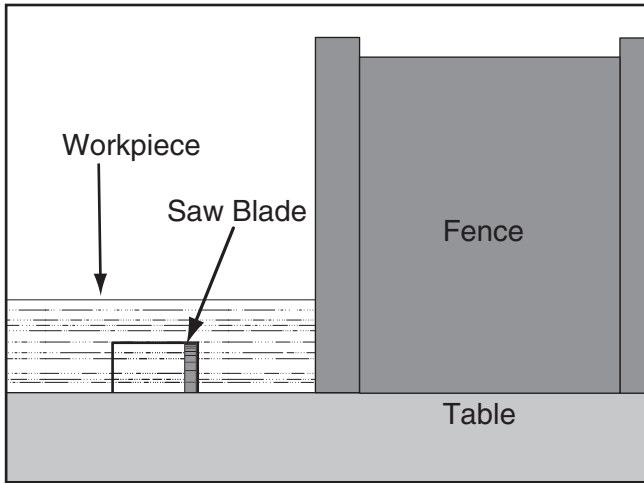

Figure 48. Single-blade dado first cut.

- Reconnect the saw to the power source and turn the saw **ON**. Allow the blade to reach full speed.
- Perform the cutting operation.
- Re-adjust the fence so the blade is aligned with the other edge of the intended dado channel (**Figure 49**).

Note: *Be sure to keep the cuts within your marks; otherwise, the dado will be too big.*

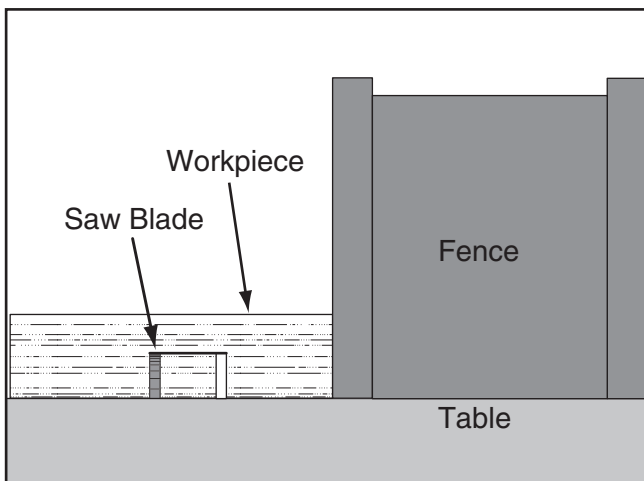

Figure 49. Single-blade dado second cut.

- Continue making cuts toward the center of the dado until the dado is complete.

Rabbet Cutting

! CAUTION

You may experience kickback during this procedure. Stand to the side of the blade and wear safety glasses or a face shield to prevent injury when cutting rabbets.

Commonly used in furniture joinery, a rabbet is an L-shaped groove cut in the edge of the workpiece. Rabbets can be cut with either a dado blade or a standard saw blade. The optional dado insert, Model H9910, (see **Page 43**) must be installed during rabbeting operations.

Rabbet cutting on the edge of the workpiece requires a sacrificial fence attachment as shown in **Figure 50**.

To cut rabbets with the dado blade:

- DISCONNECT THE SAW FROM POWER!
- Install the optional dado insert.
- Make the sacrificial fence the same length as the fence and $\frac{3}{4}$ " thick.
- Attach it to the fence with screws or clamps as shown in **Figure 50**, making sure they are all secure and tight.

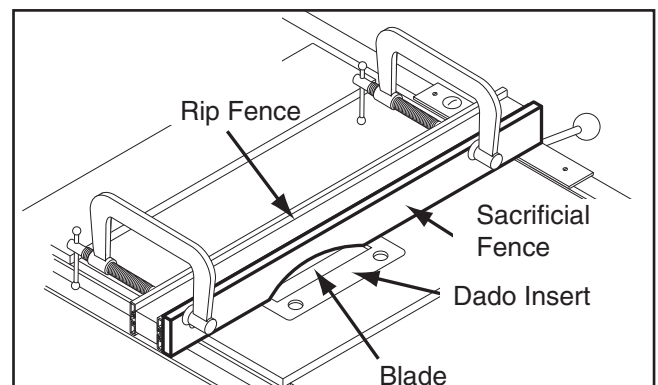

Figure 50. Sacrificial fence.



⚠ CAUTION

Always use push sticks, featherboards, push paddles and other safety accessories whenever possible to increase safety and control during operations which require that the blade guard and splitter must be removed from the saw. **ALWAYS** replace the blade guard after dadoing is complete.

5. Adjust the fence, turn the saw **ON**, raise the blade into the sacrificial fence to the height needed for the rabbeting operation, and turn the saw **OFF**.
6. Align the workpiece to perform the cutting operation as shown in **Figure 51**.

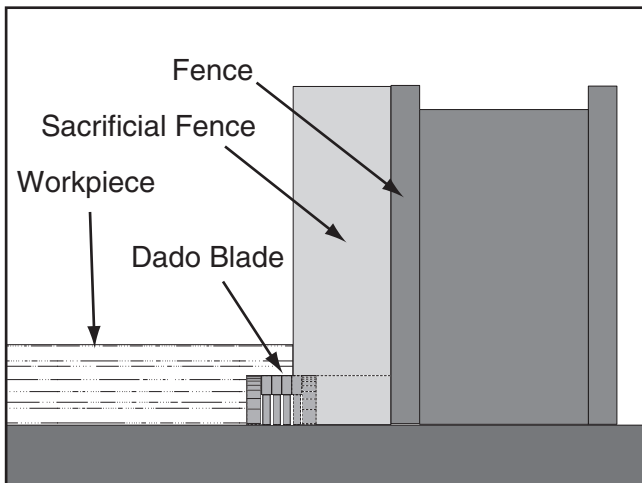

Figure 51. Rabbet cutting.

⚠ WARNING

The danger of kickback increases relative to the depth and width of a cut. Reduce the risk of kickback by making multiple passes to achieve the desired depth of cut. Failure to follow these warnings could result in serious personal injury.

7. Reconnect the saw to the power source and turn the saw **ON**.
8. When the blade has reached full speed, perform a test cut with a scrap piece of wood.
9. If the cut is satisfactory, repeat the cut with the final workpiece.

To cut rabbets with the standard blade:

Note: Cutting rabbets with a standard saw blade **DOES NOT** require the use of a sacrificial fence.

Note: Reduce motor overloading and blade wear by using a ripping blade. Ripping blades are designed to clear the sawdust quickly.

1. DISCONNECT THE SAW FROM POWER!
2. Ensure that the riving knife and standard insert are installed.
3. Clearly mark the width of the rabbet cut on the workpiece.
Note: Include marks on the edge of the workpiece to clearly identify the intended cut while it is laying flat on the saw table.
4. Raise the blade up to the desired depth of cut (depth of rabbet channel desired). When cutting deep rabbets, take more than one pass to reduce the risk of kickback.

⚠ WARNING

The danger of kickback increases relative to the depth of a cut. Reduce the risk of kickback by making multiple passes to achieve the desired depth of cut. Failure to follow these warnings could result in serious personal injury.

5. Adjust the fence so the blade is aligned with the inside of your rabbet channel as shown in **Figure 52**.

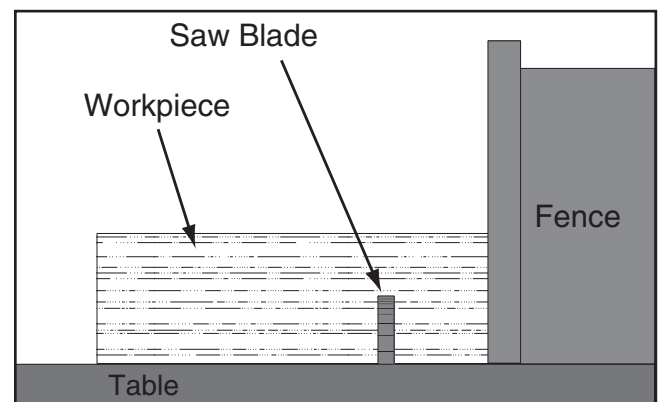

Figure 52. Rabbet cutting with a standard blade.



6. Reconnect the saw to the power source and turn the saw **ON**.
7. When the blade has reached full speed, perform a test cut with a scrap piece of wood.
8. If the cut is satisfactory, repeat the cut with the final workpiece.
9. Stand the workpiece on edge as shown in **Figure 53**.

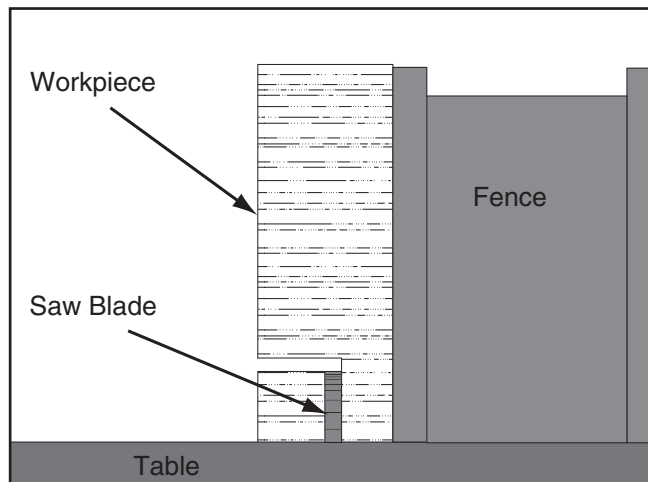

Figure 53. Second cut to create a rabbet.

10. Adjust the saw blade height to intersect with the first cut.
11. Perform the second cut to complete the rabbet.

Resawing

!WARNING

Resawing on a table saw increases the chances of kickback. Serious injury can be caused by kickback. Kickback is a high-speed expulsion of stock from the tablesaw toward an operator. The operator or bystanders may be struck by flying stock, or the operator's hands can be pulled into the blade during the kickback.

!WARNING

Resawing operations require proper procedures to avoid serious injury. Extra care must be taken to prevent kickback when resawing. Any tilting or movement of the workpiece away from the fence will cause kickback. Be certain that stock is flat and straight. Failure to follow these warnings could result in serious personal injury.

Resawing is the process of cutting a thick piece of stock into one or more thinner pieces. **Bandsaws are ideal for resawing and the process is fairly easy and safe. A table saw is not intended for resawing and the process is difficult and extremely dangerous.** Resawing on the table saw often binds the blade, causing kickback. The risk of kickback increases relative to the depth of a cut. Kickback is more dangerous when resawing on a table saw because the anti-kickback devices and blade guard must be removed, leaving no protection between your hands and the saw blade. Kickback can pull the operator's hands into the blade, or the operator or bystanders may be hit by flying stock. **DO NOT** resaw on a table saw without using a resaw barrier. **DO NOT** resaw on a table saw without wearing a full face shield.

The following instructions describe how to build a resaw barrier, add an auxiliary fence to your standard fence, and more safely perform resawing operations.

Note: *This table saw can only resaw wood that is less than 8" tall.*



Resaw Barrier

The resaw barrier shown in **Figure 54** holds the workpiece vertical, keeps the workpiece aligned with the fence, and keeps your hands away from the blade.

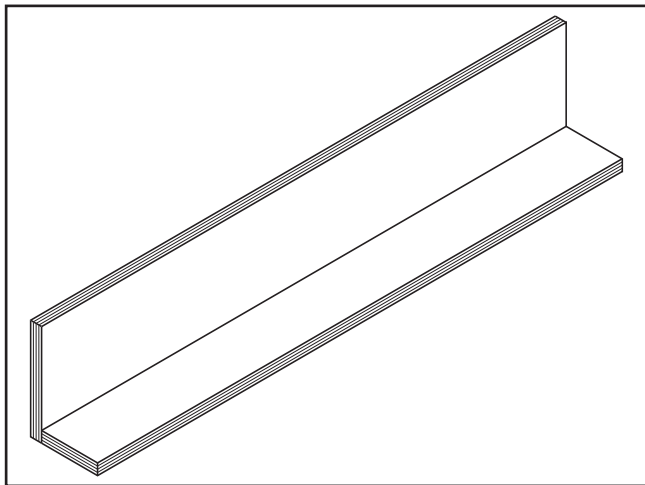

Figure 54. Resawing barrier.

Components Needed for the Resaw Barrier:

Hardwood or Plywood $\frac{3}{4}$ " x $7\frac{1}{2}$ " x $40\frac{1}{4}$ "	1
Hardwood or Plywood $\frac{3}{4}$ " x 3" x $40\frac{1}{4}$ "	1
Wood Screws $\frac{1}{4}$ -20 x 2"	8
Wood Glue	As Needed

Tools Needed for the Resaw Barrier:

Table Saw	1
Jointer and Planer	Recommended
Clamps	2 Minimum
Drill and Drill Bits	1

To build the resaw barrier:

1. Cut two boards to $\frac{3}{4}$ " x $7\frac{1}{2}$ " x $40\frac{1}{4}$ " and $\frac{3}{4}$ " x 3" x $40\frac{1}{4}$ ". If you are using hardwood, cut the boards oversize, then joint and plane the boards to the correct size to make sure the boards are square and flat.

Note: Only use furniture grade plywood or kiln dried hardwood to prevent warping.

2. Pre-drill and countersink 8 holes approximately $\frac{3}{8}$ " from the bottom of the $7\frac{1}{2}$ " tall board.

3. Glue the end of the 3" board, then clamp the boards at a 90° angle with the larger board in the vertical position as shown in **Figure 55**.

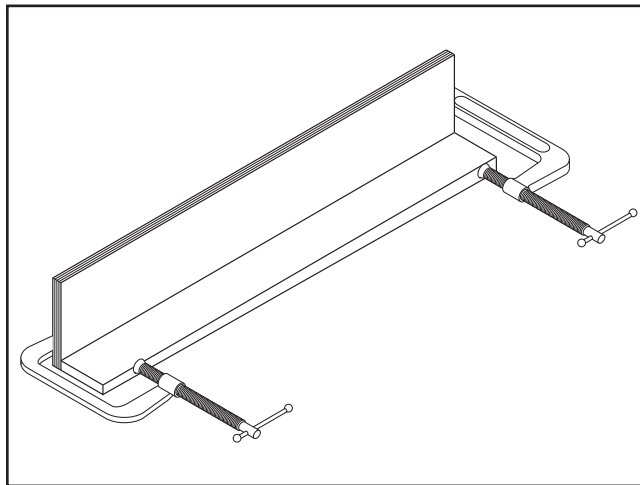

Figure 55. Clamping the resawing barrier.

4. Secure the joint with the wood screws.

Auxiliary Fence

The auxiliary fence is necessary if you are resawing a workpiece that is taller than it is wide. It should be no less than $\frac{1}{2}$ " shorter than the board to be resawn.

Components Needed for the Auxiliary Fence:

Hardwood or Plywood $\frac{3}{4}$ " x (Height) x $40\frac{1}{4}$ "	1
Flat Head Screws M8-1.25 x 25 (Not included)	4
Hex Nuts M8-1.25 (Included)	4

Tools Needed for the Resaw Barrier:

Table Saw	1
Jointer and Planer	Recommended
Clamps	2 Minimum
Drill and Drill Bits	1

To build the auxiliary fence:

1. Cut a $\frac{3}{4}$ " thick board $40\frac{1}{4}$ " long, and cut a height no less than $\frac{1}{2}$ " shorter than the board to be resawn. If you are using hardwood, cut the board oversize, then joint and plane the board to the correct size to make sure the board is square and flat.

Note: Only use furniture grade plywood or kiln dried hardwood to prevent warping.

2. Pre-drill and countersink four holes $1\frac{1}{4}$ " from the bottom of the board.



3. Pull an end cap off of the standard fence, then remove four hex nuts, flat washers, hex bolts and one side of the fence facing from the fence body.
4. Thread the flat head screws through the auxiliary fence and into the hex nuts in the standard fence body, and tighten securely as shown in **Figure 56**.

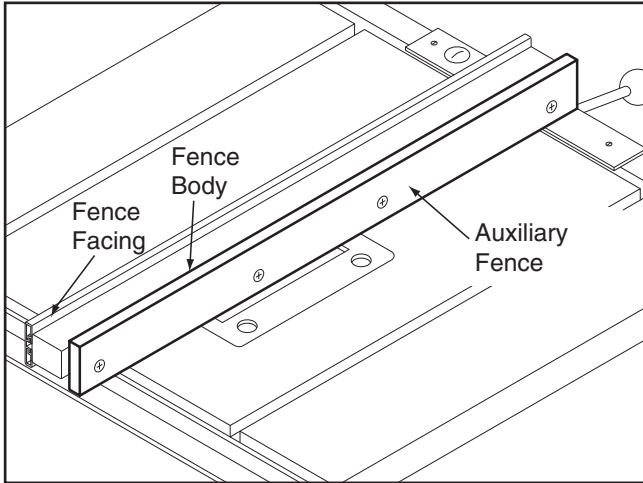

Figure 56. Auxiliary fence.

Resawing Operations

The table saw motor is pushed to its limits when resawing. If the motor starts to bog down, slow down your feed rate. Motor overloading and blade wear can be reduced by using a ripping blade. Ripping blades are designed to clear the sawdust quickly.

Components Needed for Resawing:

Zero Clearance Insert.....	1
Ripping Blade 12".....	1
Clamps	2
Shop Made Auxiliary Fence	1
Shop Made Resaw Barrier.....	1

!WARNING

You may experience kickback during this procedure. Stand to the side of the blade and wear a full face shield to prevent injury when resawing.

To perform resawing operations:

1. DISCONNECT THE SAW FROM POWER!
2. Remove the standard table insert and the blade guard/splitter, and install the riving knife. Install a ripping blade and a zero clearance table insert. Then lower the blade below the table surface.
3. Attach the auxiliary fence to the standard fence and set it to the desired width.

Note: Account for blade kerf, the rough cut made by the blade, and the inaccuracy of the fence scale when the auxiliary fence is installed when figuring out the correct width.

4. Place the workpiece against the fence and slide the resaw barrier against the workpiece. Now clamp the resaw barrier to the top of the table saw (see **Figure 57**).
5. Slide the workpiece over the blade to make sure it moves smoothly.
6. Raise the blade approximately an inch, or close to half the height of the workpiece (**Figure 57**), whichever is less.

!WARNING

The danger of kickback increases relative to the depth of a cut. Reduce the risk of kickback by making multiple passes to achieve the desired depth of cut. Failure to follow these warnings could result in serious personal injury.



CAUTION

Always use push sticks or push paddles to increase safety and control during operations which require that the blade guard and splitter must be removed from the saw. **ALWAYS** replace the blade guard after resawing is complete.

7. Plug in the table saw, turn it **ON**, and use a push stick to feed the workpiece through the blade using a slow, steady feed rate.
8. Flip the workpiece end for end, keeping the same side against the fence, and run the workpiece through the blade.
9. Repeat **Steps 6–8** until the blade is close to half of the height of the board to be resawn. The ideal completed resaw cut will leave an $\frac{1}{8}$ " connection when the resawing is complete as shown in **Figure 57**. Leaving an $\frac{1}{8}$ " connection will reduce the risk of kickback.

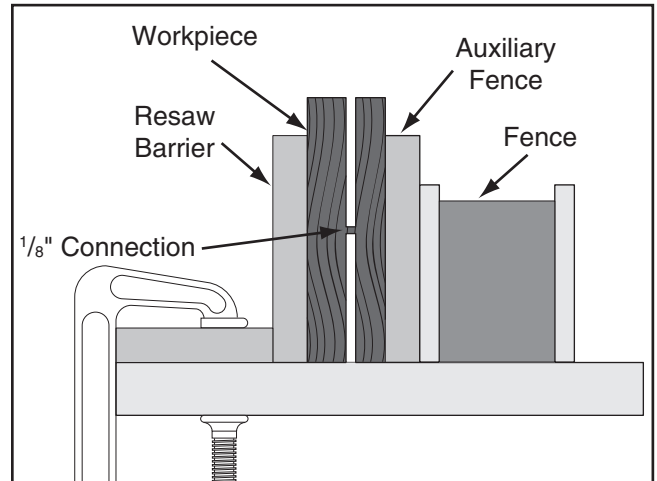

Figure 57. Ideal completed resaw cut.

10. Turn **OFF** the table saw, then separate the parts of the workpiece and hand plane the remaining ridge.
11. When finished resawing, remove the resaw barrier and auxiliary fence and re-install the blade guard/splitter or riving knife and standard table insert.



SECTION 5: ACCESSORIES

H8084—Rear Tool Box for G0605X/G0606X
H8085—Front Tool Box for G0605X/G0606X
Made specially to fit the G0605X/G0606X saws. These heavy-duty tool boxes feature powder coated paint and ball bearing slides. Model H8084, 32"L x 22½"H x 15"D; Model H8085, 25"L x 22½"H x 15"D.



Figure 58. Model H8084, H8085 Tool Boxes.

G7895—Citrus Degreaser
This citrus based degreaser is perfect for cleaning cosmoline off of new equipment. It also works for cleaning auto parts, tools, concrete, and porcelain surfaces. Natural, safe for the environment, and contains no CFC's.



Figure 59. G7895 Citrus Degreaser.

H1234—Table Saw Bench Guide
Like having a master woodworker by your side. Inside this book you'll find great ideas for dozens of shop-made accessories and jigs, in-depth maintenance procedures, loads of safety tips and tricks, and picture-laden walkthroughs for nearly every cut imaginable. Also includes a blade section that covers selection, sharpening, care, troubleshooting, etc. A must have! 160 pages.

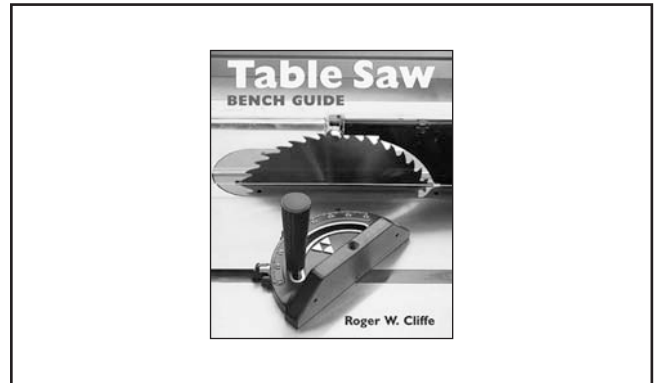

Figure 60. H1234 Table Saw Bench Guide.

H9910—Phenolic Dado Insert for G0605X/G0606X

H9911—Zero Clearance Insert for G0605X/G0606X

Made especially for the G0605X/G0606X table saw. Height is easily adjustable. Special phenolic material.

H7583—Grizzly Tenoning Jig
Our fully adjustable tenoning jig handles stock up to 3¼" thick and features an adjustable bevel angle with a 90° to 75° range. The two large grip handles, adjustable guide bar, multi-position control levers, and extra large clamping handwheel will ensure accurate and repeatable results. A top seller!

Call 1-800-523-4777 To Order



- G5562—SLIPIT® 1 Qt. Gel
- G5563—SLIPIT® 12 oz Spray
- G2871—Boeshield® T-9 12 oz Spray
- G2870—Boeshield® T-9 4 oz Spray
- H3788—G96® Gun Treatment 12 oz Spray
- H3789—G96® Gun Treatment 4.5 oz Spray



Figure 61. Recommended products for protecting your cast iron table top.

- G7581—Superbar™
- G7582—Master Plate

The miter slot mounted Superbar™ will align, tune and calibrate your tablesaw to within ±.001 in just minutes. Replace your tablesaw blade when calibrating the double disk ground Master Plate for a precision measurement, with no runout!

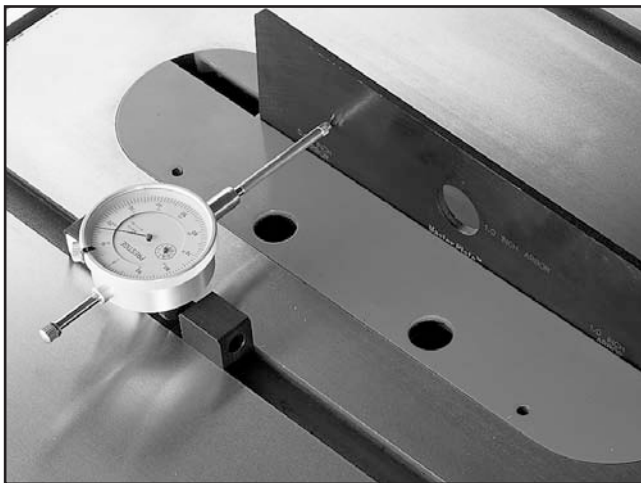

Figure 62. Superbar™ and Master Plate.

Call 1-800-523-4777 To Order

- Carbide-Tipped Saw Blades (ATB)**
- G4808—12" Ripping, 40T
- G4809—12" General Purpose, 60T
- G4810—12" Fine Finishing/Cabinet Work, 80T

These ATB blades are manufactured to close tolerances and are fully balanced before leaving the factory. All the carbide-tipped teeth are precisely ground to give a smooth cut every time. The pattern of the teeth is alternate top bevel and the saw kerf is approx. 1/8". These blades have proven themselves in thousands of cabinet shops around the country. Manufactured for heavy-duty use.



Figure 63. Carbide-tipped saw blades.

- G2370—SHOP FOX® Board Buddies

These unique hold downs only turn in one direction to prevent kickback. Adjustable height, spring loaded wheels are designed to hold your workpiece tight against the table and rip fence and are made of a special composition that will not mark your work.



Figure 64. G2370 SHOP FOX® Board Buddies.



SECTION 6: MAINTENANCE



Schedule

For optimum performance from your machine, follow this maintenance schedule and refer to any specific instructions given in this section.

Daily

- Check guard operation.
- Inspect blades for damage or wear.
- Check for loose mounting bolts/arbor nut.
- Check cords, plugs, and switch for damage.
- Any other condition that could hamper the safe operation of this machine.
- Vacuum dust buildup from inside the cabinet and off of the motor after use.
- Wipe the table clean after every use—this ensures moisture from wood dust does not remain on bare metal surfaces.

Weekly

- Wipe down the table surface and grooves with a lubricant and rust preventive such as SLIPIT®.
- Clean the pitch and resin from the saw blade with a cleaner like OxiSolv® Blade & Bit Cleaner.

Monthly

- Check the flat belt for damage or wear.

Cleaning

Cleaning the Model G0605X/G0606X is relatively easy. Vacuum excess wood chips and sawdust, and wipe off the remaining dust with a dry cloth. If any resin has built up, use a resin dissolving cleaner to remove it. Treat all unpainted cast iron and steel with a non-staining lubricant after cleaning.

Occasionally it will become necessary to clean the internal parts with more than a vacuum. To do this, remove the table top and clean the internal parts with citrus cleaner or mineral spirits and a stiff wire brush or steel wool. **DO NOT USE WATER—WATER WILL CAUSE CAST IRON TO RUST.** Make sure the internal workings are dry before using the saw again, so that wood dust will not accumulate. If any essential lubrication is removed during cleaning, re-lubricate those areas.

Lubrication

Lubricate the areas indicated below every 6–12 months, depending on frequency of use. These areas can be reached through the motor cover opening or the blade opening. Check all adjustments after lubricating.

Lubricate the following components with multi-purpose grease:

1. **Trunnion and trunnion slide** (where Parts 13 and 42 slide each other, on **Page 61**).
2. **The worm gear, bevel gears, acme screw and shafts** (Parts 99, 33, 38, 6, and 40 on **Page 61**).

Note: *Using a small brush to apply the grease may be easier than using your fingers.*



SECTION 7: SERVICE

Review the troubleshooting and procedures in this section to fix your machine if a problem develops. If you need replacement parts or you are unsure of your repair skills, then feel free to call our Technical Support at (570) 546-9663.

Troubleshooting

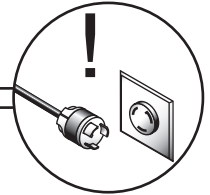

Motor & Electrical

Symptom	Possible Cause	Possible Solution
Machine does not start or a breaker trips.	<ol style="list-style-type: none"> 1. Plug/receptacle is at fault or wired incorrectly. 2. Start capacitor is at fault (G0605X only). 3. Motor connection wired incorrectly. 4. Thermal overload relay has tripped. 5. Contactor not getting energized/has burnt contacts. 6. Wall fuse/circuit breaker is blown/tripped. 7. Power supply is at fault/switched OFF. 8. Motor ON button or ON/OFF switch is at fault. 9. Centrifugal Switch is at fault (G0605X only). 10. Wiring is open/has high resistance. 11. Motor is at fault. 12. Start delay module is at fault. 	<ol style="list-style-type: none"> 1. Test for good contacts; correct the wiring. 2. Test/replace if faulty. 3. Correct motor wiring connections. 4. Unplug machine, open magnetic switch cover, turn amperage dial on Thermal Protection Circuit Breaker to a higher amperage setting. 5. Test for power on all legs and contactor operation. Replace unit if faulty. 6. Ensure correct size for machine load (refer to Page 12); replace weak breaker. 7. Ensure hot lines have correct voltage on all legs and main power supply is switched ON. 8. Replace faulty ON button or ON/OFF switch. 9. Adjust/replace the centrifugal switch if available. 10. Check for broken wires or disconnected/corroded connections, and repair/replace as necessary. 11. Test/repair/replace. 12. Adjust to correct delay; replace module.
Machine stalls or is underpowered.	<ol style="list-style-type: none"> 1. Applying too much pressure to workpiece. 2. Run capacitor is at fault (G0605X only). 3. Belt slipping. 4. Motor connection is wired incorrectly. 5. Plug/receptacle is at fault. 6. Motor bearings are at fault. 7. Motor has overheated. 8. Contactor not getting energized or has poor contacts. 9. Motor is at fault. 10. Centrifugal switch is at fault (G0605X). 11. Start delay module at fault (G0606X only). 	<ol style="list-style-type: none"> 1. Use sharp blade, and reduce the feed rate. 2. Test/repair/replace. 3. Replace bad belt, align pulleys, and re-tension. 4. Correct motor wiring connections. 5. Test for good contacts; correct the wiring. 6. Test by rotating shaft; rotational grinding/loose shaft requires bearing replacement. 7. Clean off motor, let cool, and reduce workload. 8. Test for power on all legs and contactor operation. Replace if faulty. 9. Test/repair/replace. 10. Adjust/replace centrifugal switch if available. 11. Adjust to correct delay; replace module.



Symptom	Possible Cause	Possible Solution
Machine has vibration or noisy operation.	<ol style="list-style-type: none"> 1. Motor or component is loose. 2. Flat belt worn or loose. 3. Motor fan is rubbing on fan cover. 4. Pulley is loose. 5. Machine sits unevenly on floor. 6. Arbor bearings are at fault. 7. Arbor pulley is loose. 8. Motor bearings are at fault. 9. Blade is at fault. 10. Loose arbor nut 11. Centrifugal switch (G0605X only). 	<ol style="list-style-type: none"> 1. Inspect/replace stripped or damaged bolts/nuts, and re-tighten with thread locking fluid. 2. Inspect/replace flat belt with new one (refer to Page 48). 3. Replace dented fan cover; replace loose/damaged fan. 4. Realign/replace shaft, pulley, set screw, and key as required. 5. Relocate/shim machine. 6. Replace arbor housing bearings; replace arbor. 7. Retighten/replace arbor pulley with shaft and thread locking liquid. 8. Test by rotating shaft; rotational grinding/loose shaft requires bearing replacement. 9. Replace warped, bent, or twisted blade; sharpen dull blade. 10. Tighten the arbor nut. 11. Replace centrifugal switch.

Table Saw Operations

Symptom	Possible Cause	Possible Solution
Blade is not aligned with miter slot or fence.	<ol style="list-style-type: none"> 1. Blade is warped. 2. Table top is not parallel to blade. 3. Fence is not parallel to blade. 	<ol style="list-style-type: none"> 1. Replace blade (Page 22). 2. Make table parallel to blade (Page 52). 3. Make fence parallel to blade (Page 54).
Blade does not reach 90°.	<ol style="list-style-type: none"> 1. 90° stop bolt is out of adjustment. 2. Sawdust loaded up on positive stop. 	<ol style="list-style-type: none"> 1. Adjust 90° stop bolt (Page 50). 2. Clean sawdust off positive stop.
Blade hits insert at 45°.	<ol style="list-style-type: none"> 1. 45° stop bolt is out of adjustment. 2. Hole in insert is inadequate. 3. Table out of alignment. 4. Blade position is incorrect. 	<ol style="list-style-type: none"> 1. Adjust 45° stop bolt (Page 50). 2. File or mill the hole in the insert. 3. Align blade to the table (Page 52). 4. Adjust blade position.
Board binds or burns when feeding through tablesaw.	<ol style="list-style-type: none"> 1. Dull blade. 2. Blade is warped. 3. Fence is not parallel to blade. 4. Table top is not parallel to blade. 	<ol style="list-style-type: none"> 1. Replace blade. 2. Replace blade (Page 22). 3. Make fence parallel to blade (Page 54). 4. Make table parallel to blade (Page 52).



Replacing Flat Belt

To ensure optimum power transmission from the motor to the blade, the flat belt must be in good condition. Replace the belt if it becomes cracked, frayed, or glazed.

Tools Needed	Qty
Arbor Wrenches	2
Hex Wrench 4mm.....	1
Phillips Head Screwdriver	1
Wood Block 12" Long 4x4	1
Wrench or Socket 14mm.....	1
Wrench or Socket 10mm.....	1

To remove the flat belt:

1. DISCONNECT THE SAW FROM POWER!
2. Raise the motor all the way up, tilt it to 0°, and open the motor cover.
3. Loosen the three motor mounting hex nuts, shown in **Figure 65**, two turns, and place a 4x4 block between the cabinet and bottom of the motor, as shown in **Figure 66**.

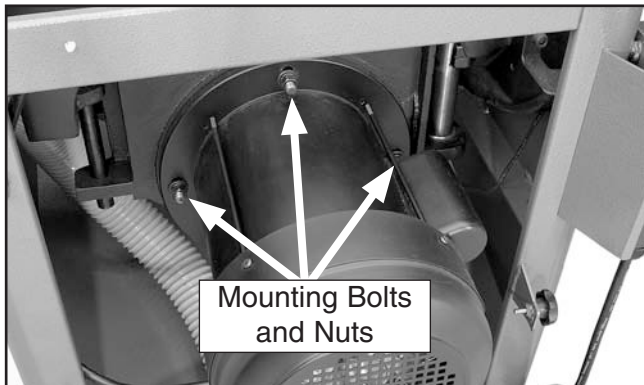

Figure 65. Motor mounting bolts.

4. Lower the arbor assembly until the motor rests on the wood block, as shown in **Figure 66**, to reduce tension on the flat belt. Be careful not to damage the motor, and do not force the arbor down further when it becomes difficult to move the handwheel.

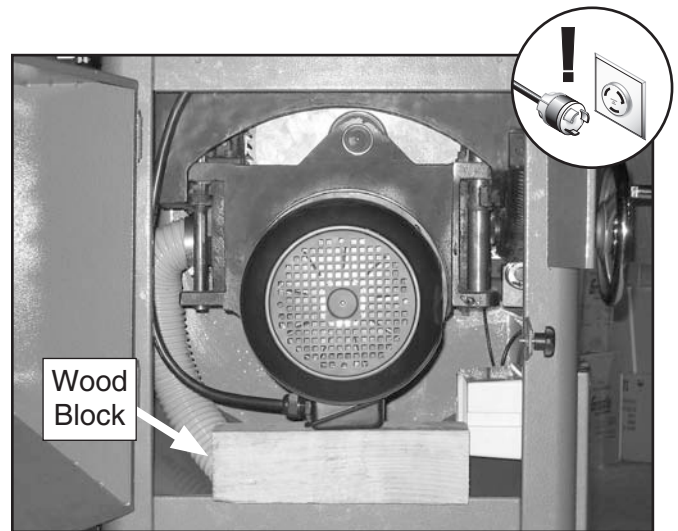

Figure 66. Motor resting on wood block.

5. Tighten the motor mounting nuts to hold the motor in place.
6. Raise the blade all the way up and remove the wood block, table insert, blade guard and splitter or riving knife, arbor nut, flange, and the saw blade.
7. Tilt the arbor to 20°.
8. Remove the deflector plate and the hex bolts and flat washers securing it (**Figure 67**).

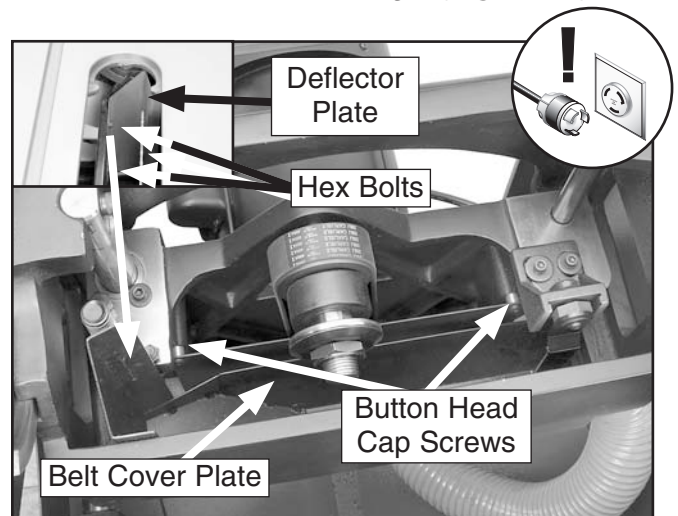

Figure 67. Belt cover plate and top button head cap screws (table removed for clarity).

9. Remove the upper two button head cap screws, and remove the spacers on the belt cover plate shown in **Figure 67**.



10. Lower the arbor down all the way, remove the button head cap screws on the lower part of the belt cover plate, the spacers, and the cover plate.

11. Roll the belt off of the upper and lower pulleys. Be careful not to pinch your fingers.

To install the new belt:

1. Place the new flat belt onto the lower pulley so it engages one or two grooves.
2. Push the belt inward and roll it onto the top pulley. Continue pushing the belt and rotating it up and down (**Figure 68**) until it is centered on both pulleys.

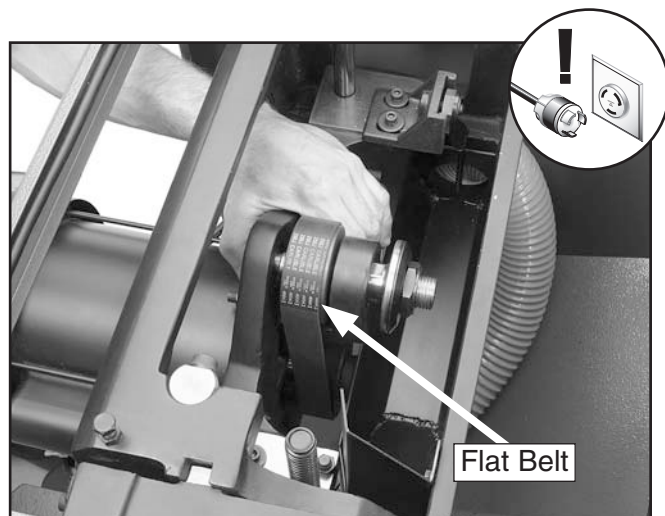

Figure 68. Installing flat belt (table removed for clarity.)

3. Reinstall two button head cap screws and spacers onto the lower part of the belt cover plate.
4. Raise the blade all the way up.
5. Perform **Steps 6-9** in the previous subsection in reverse order.
6. Loosen the motor mounting hex nuts, place the wood block on top of the motor.
7. Raise the arbor assembly to tension the belt, ensuring that the wood block is between the motor and cabinet, as shown in **Figure 69**.

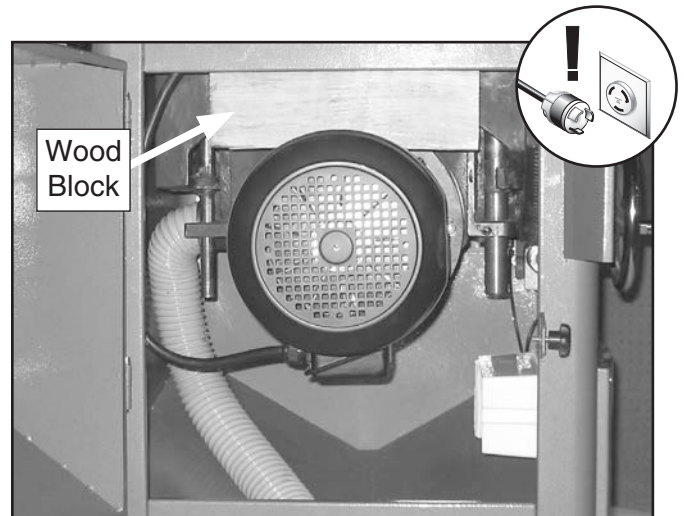

Figure 69. Using wood block to tension belt.

8. Check belt deflection, as shown in **Figure 70**.

Note: The belt is tensioned correctly when you can deflect it no more than $1/8$ ".

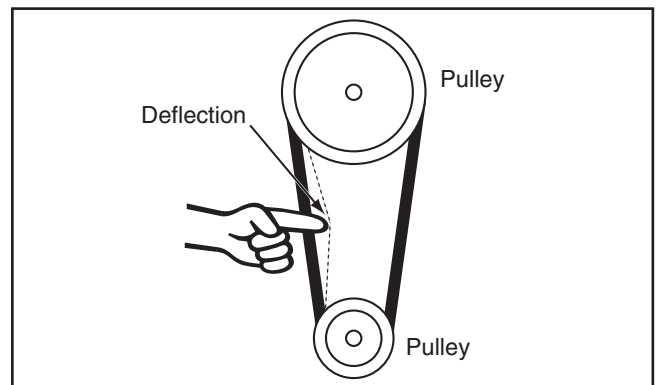

Figure 70. Checking belt deflection.

9. Tighten the motor mounting hex nuts, lower the motor, and remove the wood block.
10. Close the motor cover.



Blade Tilt Stops

The table saw features stop bolts that stop the blade exactly at 45° and 90° during blade adjustments. The stops have been set at the factory and should require no adjustments, unless you notice that your cuts are not accurate.

Tools Needed	Qty
90° Square	1
Combo Square	1
Wrench 12mm	1
Hex Wrench 4mm.....	1
Hex Wrench 5mm.....	1

To set the 90° stop bolt:

1. DISCONNECT THE SAW FROM POWER!
2. Position the blade tilt to zero (see indicator on the front of the saw), and raise the blade several inches above the table.
3. Place a machinist's square against the table and blade so it contacts the blade evenly from bottom to top. Make sure a blade tooth does not obstruct the movement of the square.

—If the blade is 90° to the table when the stop bolt contacts the underside of the table, go to **To Set the 45° Stop Bolt**.

—If the blade is not 90° to the table, you will need to adjust the 90° stop bolt.

4. Tilt the blade to 20° to access the 90° stop bolt under the table.
5. Open the motor access cover, loosen the jam nut shown in **Figures 71 & 72**, adjust the stop bolt up or down, and repeat **Steps 2-3** until the stop bolt contacts the table when the blade is at 0°.

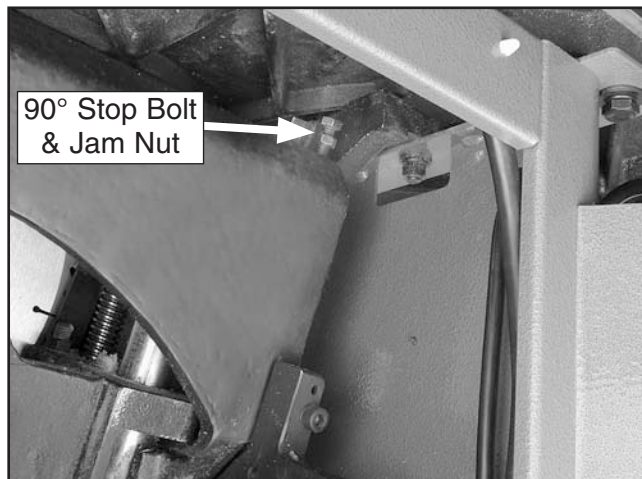

Figure 71. 90° stop bolt and jam nut.

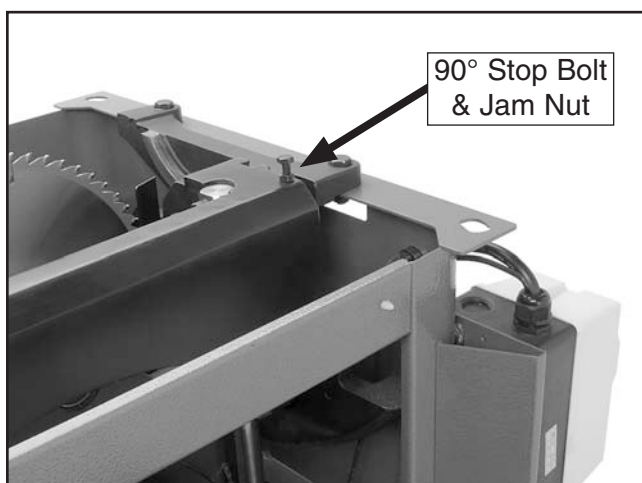

Figure 72. 90° stop bolt and jam nut (table removed for clarity).

6. Tighten the jam nut.

To set the 45° stop bolt:

1. Repeat **Steps 1-3** from the previous set of steps using a combo square set to 45°.

—If the blade is 45° to the table when the stop bolt contacts the cabinet, go to **To Adjust the Tilt Indicator Arrow**.

—If the blade is not 45° to the table go to **Step 2**.

2. Remove the blade height lock knob and handwheel.
3. Move the blade angle to 30°, or remove the panel on the right side of the cabinet to access the 45° stop bolt.



- Loosen the jam nut (**Figure 73**) on the 45° stop bolt, adjust the stop bolt up or down, then check to see if the blade is 45° to the table.

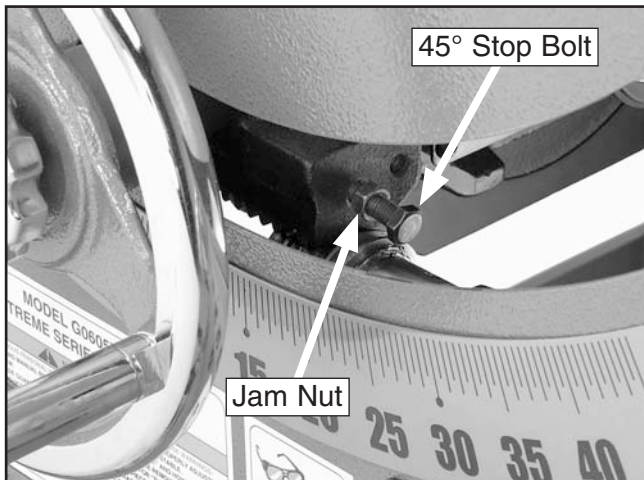

Figure 73. 45° stop bolt and jam nut.

- Continue adjusting the stop bolt until it contacts the cabinet when the blade is at 45°.
- Tighten the jam nut.

To adjust the tilt indicator arrow:

- Set the 90° stop bolt (see instructions on **Page 50**).
- Loosen the blade height handwheel set screw and remove the handwheel.
- Loosen the button head cap screw shown in **Figure 74** and move the tip of the indicator to 0°.

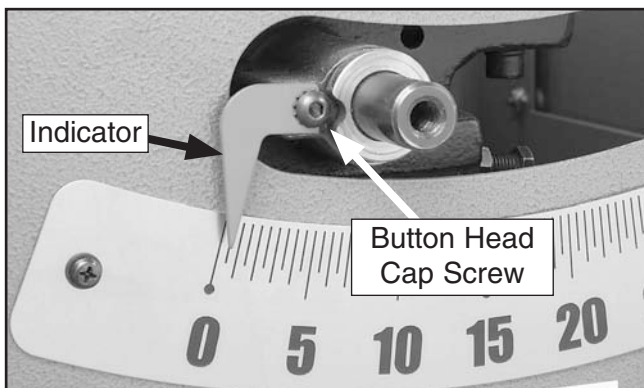

Figure 74. Tilt indicator arrow.

- Tighten the cap screw and reinstall the handwheel.

Digital Readout

The digital readout displays the current blade angle. We recommend you set the readout after verifying the 90° and 45° blade tilt stops.

To set the digital readout:

- Ensure the 90° stop bolt is set (see **Blade Tilt Stops** on **Page 50**).
- Move the blade angle to 0° and press the 0° SET button (**Figure 75**) for several seconds until the readout displays 0.00.

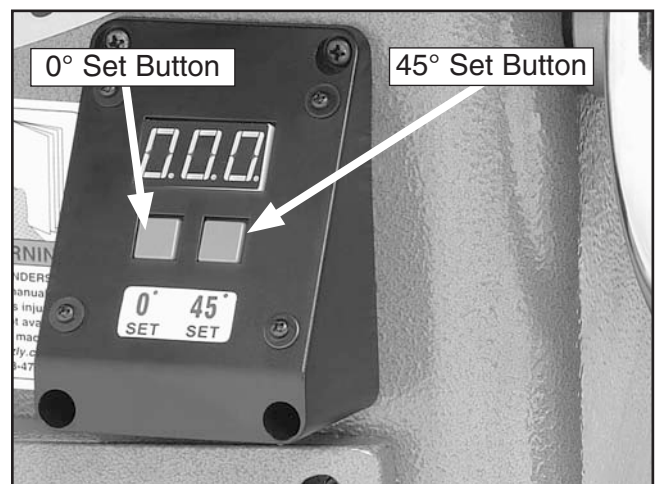

Figure 75. Digital readout.

- Move the blade angle to 45° and press the SET button for several seconds until the readout displays 45.0.

Note: If you move the blade angle handwheel when the power is disconnected, the digital readout will be incorrect when the saw is reconnected.



Miter Slot to Blade Parallelism

Tools Needed	Qty
Adjustable Square	1
Metal Shim Stock	As Needed
Marker	

Your table saw will give the best results if the miter slot and the rip fence are adjusted parallel to the blade. If either of these are not exactly parallel, your cuts and your finished work will be lower in quality, but more importantly, this condition increases the risk of kickback. Take the time to adjust your table saw properly. A few minutes now will be time well spent.

Note: For safest and most accurate adjustments, use a Superbar and Master plate (see **Figure 62** on **Page 44**).

To adjust the blade parallel to the miter slot:

1. DISCONNECT SAW FROM POWER!
2. Use an adjustable square to measure the distance from the miter slot to a carbide tip on the blade as shown in **Figure 76**. Make sure that the face of the adjustable square is even along the miter slot.

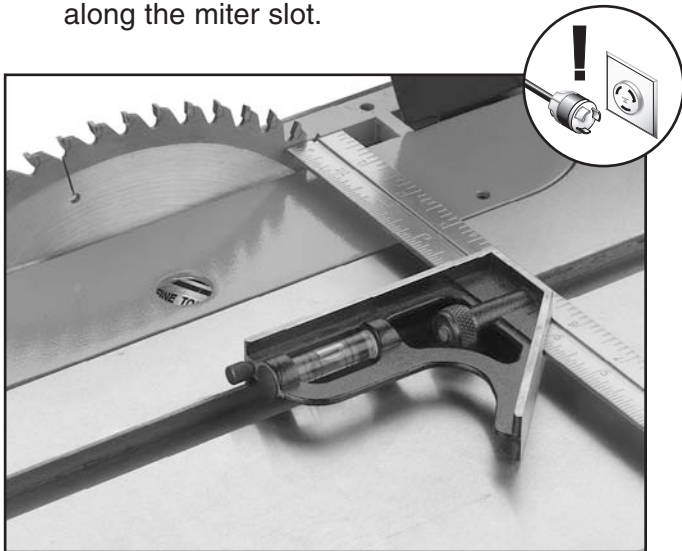

Figure 76. Example of adjusting blade to miter slot.

3. With the end of the adjustable square just touching the tip, lock the square in place. Now, mark the carbide tip with a marker where you made this measurement.

⚠ WARNING

The saw blade is dangerously sharp. Use extra care when handling the blade or working near it. Serious injury is possible.

4. Rotate that tip to the other end of the table insert.
5. Slide the adjustable square down to the other end of the table insert, and compare the distance from the marked blade tip to the end of the adjustable square.

—If the blade tip does not touch the end of the adjustable square similar to the first measurement, the table will need to be adjusted.

—If the blade tip measurement is the same on both sides, go to **Step 8**.

6. To adjust the table, loosen the three bolts in the table mounting locations (see **Figure 77**) and slightly tap the table. Repeat **Steps 2-6** until the blade and miter slot are parallel. Do not forget to tighten the table mounting bolts when finished.

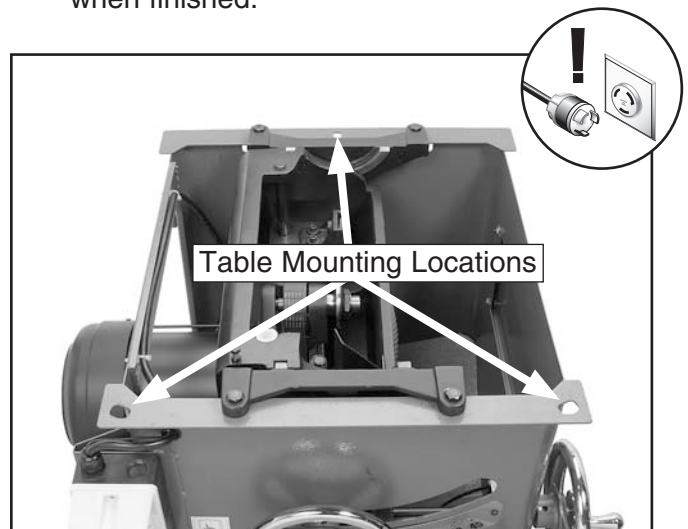

Figure 77. Table mounting bolt holes.

7. Now check to see if the blade remains parallel to the miter slot when tilted to 45°.



8. Tilt the blade to 45° and repeat **Steps 2-6**. If the blade is still parallel to the miter slot, continue on to the **Blade Alignment** procedure. Otherwise, continue with the next step.
9. If the blade was parallel to the miter slot at 90° but not at 45°, the table will need to be shimmed with metal shim stock. The shims are placed under the table over each of the three table mounting bolts.
10. Refer to **Figures 78 and 79** for shim placement. If the distance of A is shorter than B, shim(s) will need to be placed under corners #1 and #2. If the distance of B is shorter than A, shim(s) will need to be placed under corner #3. Very thin shim stock works well.
11. Tighten down one bolt a small amount and then move on to each of the others, tightening each down the same amount. Continue to rotate through the bolts, tightening them a little each time until they are all secure.
12. Now recheck the blade to miter slot at 90° and 45° by repeating **Steps 2-6**. If the distance of A and B are equal, continue to the **Blade Alignment** procedure. If the distances are still off, repeat **Steps 10-13**.
13. Once you feel you have the miter slot adjusted to the blade, recheck all measurements and be sure the table mounting bolts are secure. Also, if you ever remove the table in the future, be sure to make note of shim placements and reassemble exactly how it came apart.

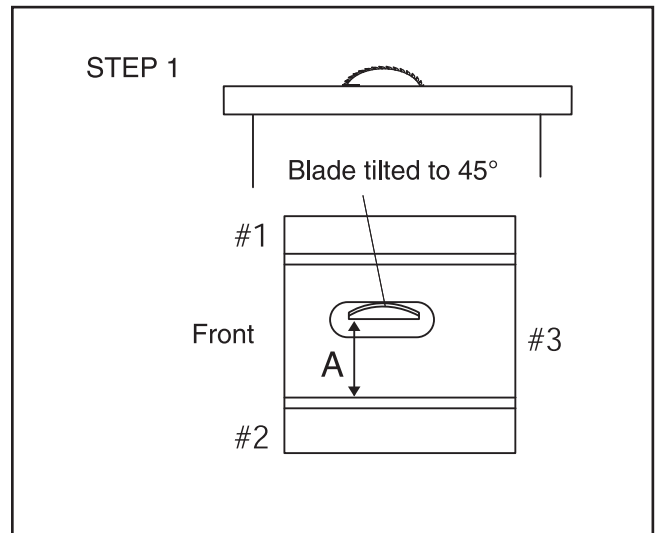

Figure 78. Shim procedure diagram A.

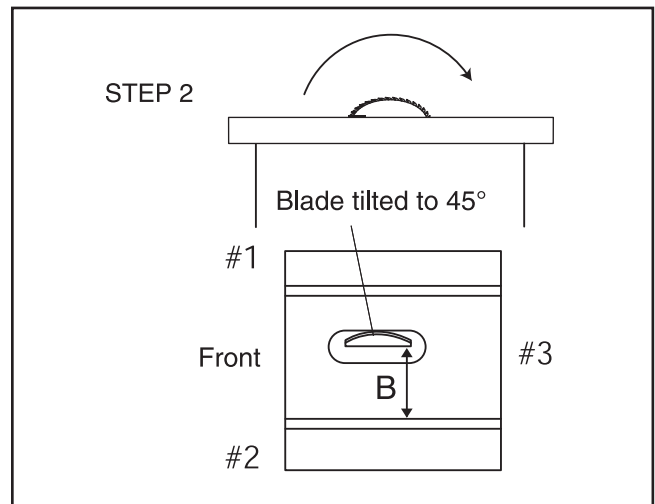

Figure 79. Shim procedure diagram B.



Blade Alignment

If the blade contacts the table insert when raised or tilted, the blade must be aligned by moving the table.

Tools Needed	Qty
Wrench 14mm.....	1

To adjust the blade by moving the table:

1. DISCONNECT THE SAW FROM POWER!
2. Loosen the three table mounting bolts (**Page 52**) and adjust the table until the blade does not contact the insert. Tighten all the mounting bolts.
3. Make sure the blade does not contact the table insert when raised or tilted. Recheck parallelism of the blade to the miter slot (see **Page 52**). Adjust as necessary until the blade does not touch the insert.

Adjusting Fence

The rip fence included with your Model G0605X/G0606X/W1762 Table Saw is designed to provide excellent ripping accuracy when properly adjusted. There are four main adjustments to concern yourself with: square, height, parallelism, and clamping pressure. Keep in mind that these adjustments are interconnected and some trial-and-error may be needed to achieve satisfactory results.

Tools Needed	Qty
Hex Wrench 4mm.....	1
Hex Wrench 6mm.....	1
Machinist Square.....	1

Square and Height

Adjust the the nylon screws (**Figure 80**) on top of the fence bracket with a 6mm hex wrench to set the fence square with the blade and set the fence height above the table.

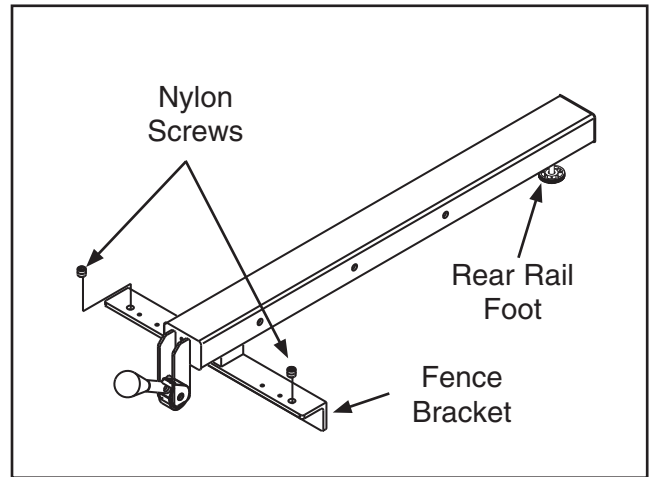

Figure 80. Nylon adjustment screws.

Place a machinist's square on the table against the side of the fence. If the square does not remain flush against both the fence and the table, adjust the nylon screws until the fence and table are square.

If the bottom surface of the fence is more than 1/16" above the table at the front or back, adjust the fence height using the nylon screws and the rear rail foot (**Figure 80**).

Clamping Pressure and Parallelism

The fence clamping mechanism can be adjusted simultaneously to set the right amount of clamping pressure to hold your fence securely, and ensure the fence is parallel to the miter slot.

Remove the fence and, using a 4mm hex wrench, adjust the set screws shown in **Figure 81** equally on the rear side of the front bracket.

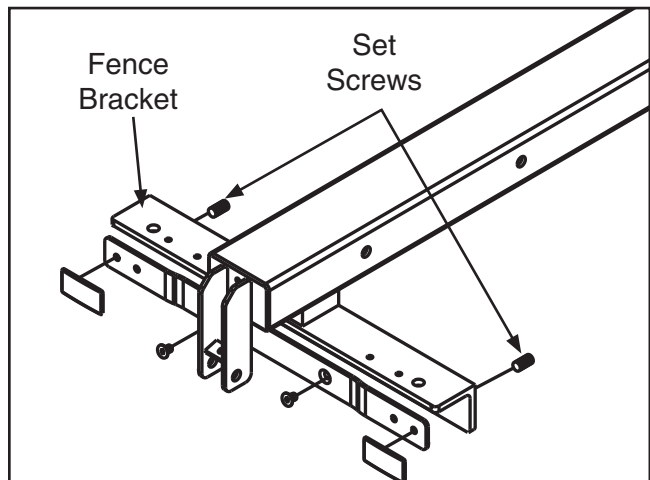

Figure 81. Set screw adjustments.



Place the fence alongside the miter slot (**Figure 82**) and check the fence to miter slot parallelism and the clamping strength.

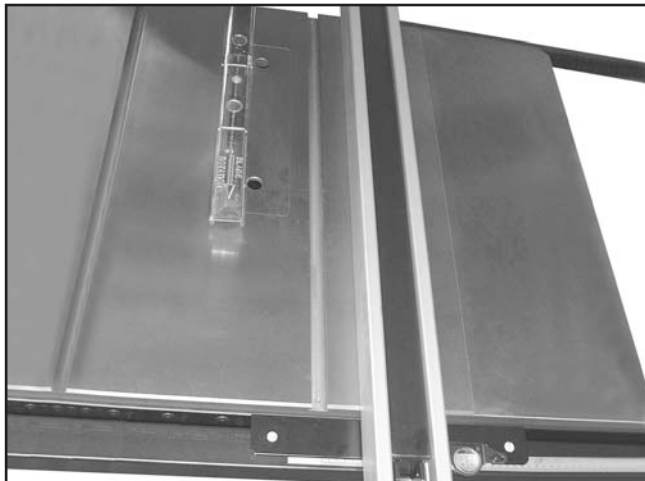

Figure 82. Example of fence aligned parallel to miter slot.

Trial-and-error will be needed to adjust the set screws so the fence is parallel to the miter slot and the clamping pressure is sufficient.

Optional: If you are cutting wet or green stock, offsetting the rear of the fence $\frac{1}{64}$ " from the blade using the set screws in **Figure 81** can help prevent the workpiece from binding and burning.

Miter Gauge

Tools Needed	Qty
Hex Wrench 2.5mm.....	1
Phillips Head Screwdriver	1
Machinist Square.....	1
Adjustable Square	1
Wrench 8mm	1

To adjust the miter gauge so it is perpendicular to the saw blade:

1. Slide the miter gauge into the miter gauge slot to the left of the blade.

2. Push in the shaft (**Figure 83**).
3. Loosen the lock knob on the miter gauge and place a square against the face of the miter body and the blade.
4. Adjust the miter body until the pointer is at 0° and there is no space between the square and the blade, then tighten the lock knob.

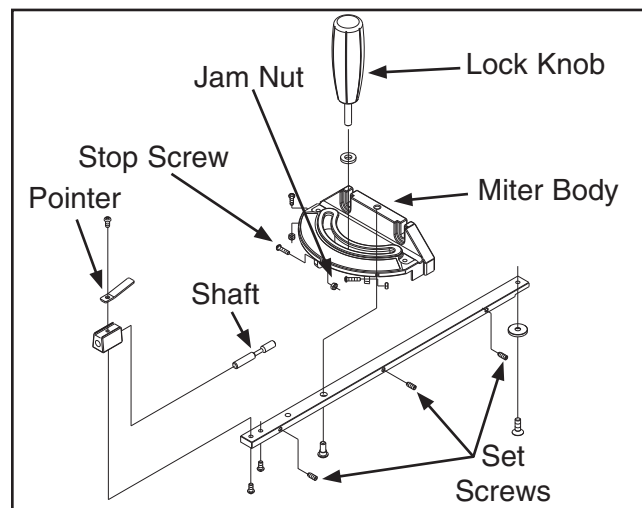

Figure 83. Miter gauge diagram.

5. Loosen the jam nut and adjust the stop screw until it is seated against the shaft (see **Figure 83** for part locations), then tighten the jam nut.
6. Loosen the screw on the front of the miter bar, adjust the pointer to 0° , then tighten the screw.
7. To adjust to 45° , follow **Steps 1-5** using an adjustable square set to 45° .
8. Double-check your adjustments at 45° and 90° to assure that you have accurately set your miter gauge.
9. To fit the miter bar tighter in the miter slot, turn the adjustment set screws shown in **Figure 83** clockwise in small increments, and test fit between adjustments until the miter gauge fits your expectations.



G0605X/G0606X Electrical Components



Figure 84. G0605X motor junction box.

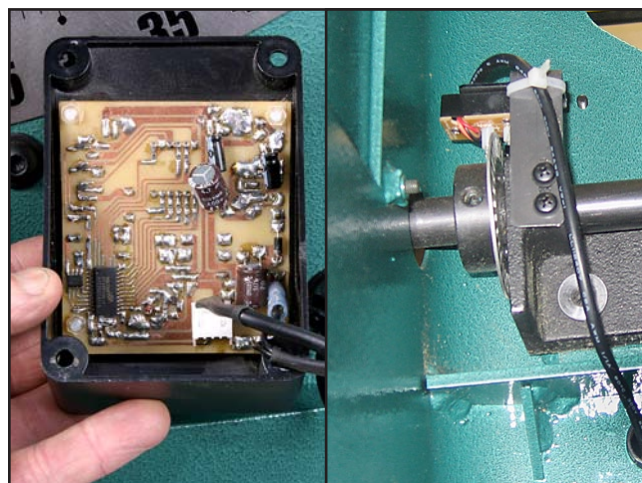

Figure 87. G0605X/G0606X digital readout and angle sensor.

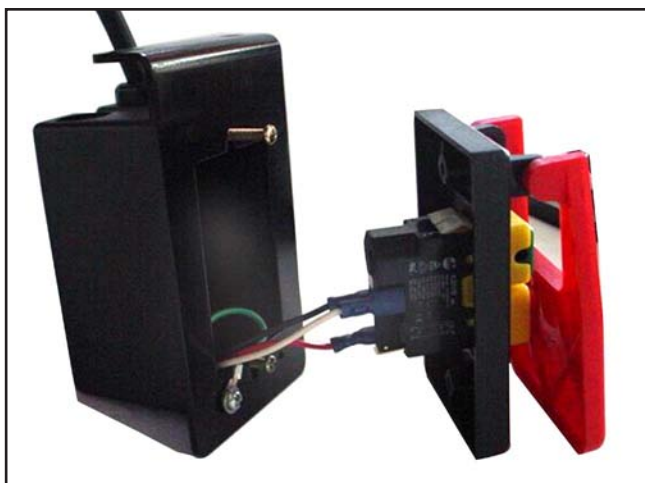

Figure 85. G0605X/G0606X switch.

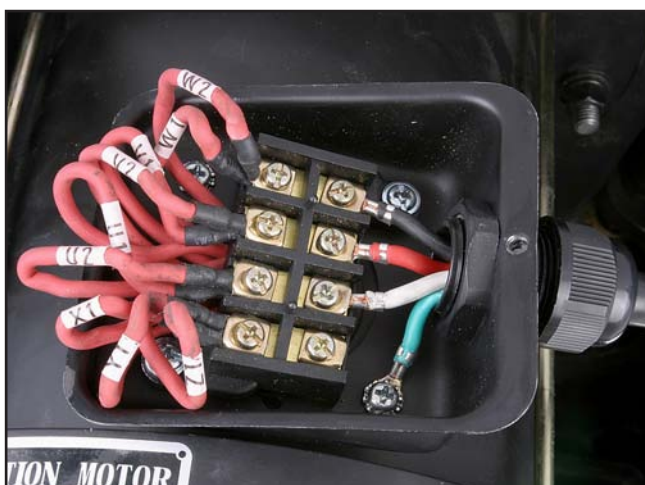

Figure 86. G0606X motor junction box.

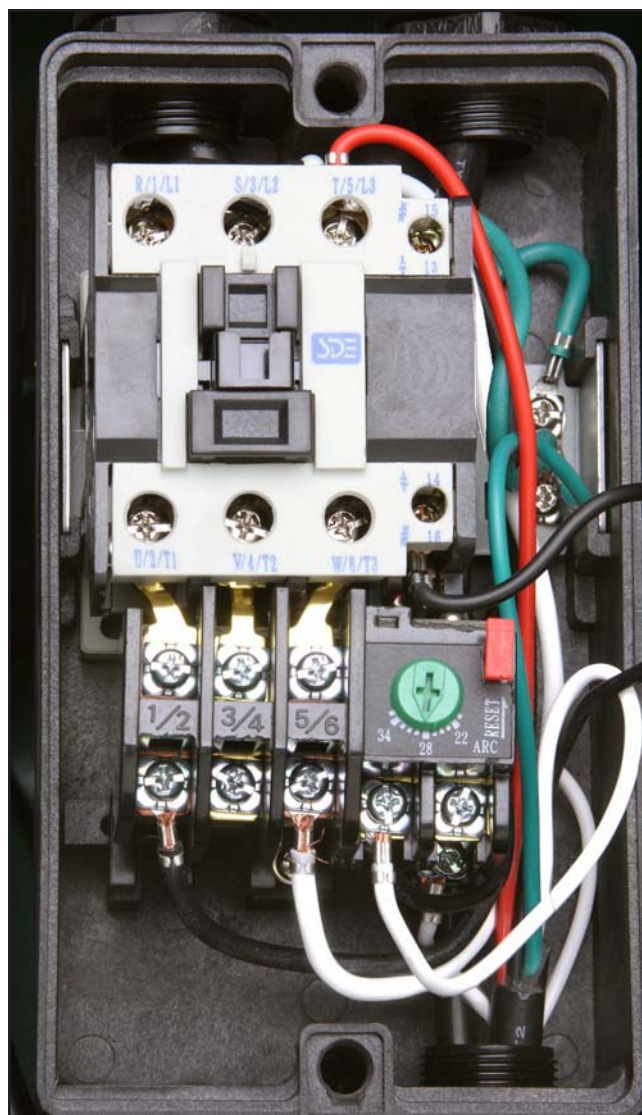

Figure 88. G0605X magnetic switch.



G0605X Wiring Diagram



Ground

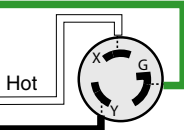

L6-30 PLUG
(as recommended)

COLOR KEY	
BLACK	Bk
WHITE	Wt
GREEN	Grn
RED	Rd
ORANGE	Or
BROWN	Br

⚠ DANGER
Disconnect power before performing any electrical service. Electricity presents serious shock hazards that will result in severe personal injury and even death!

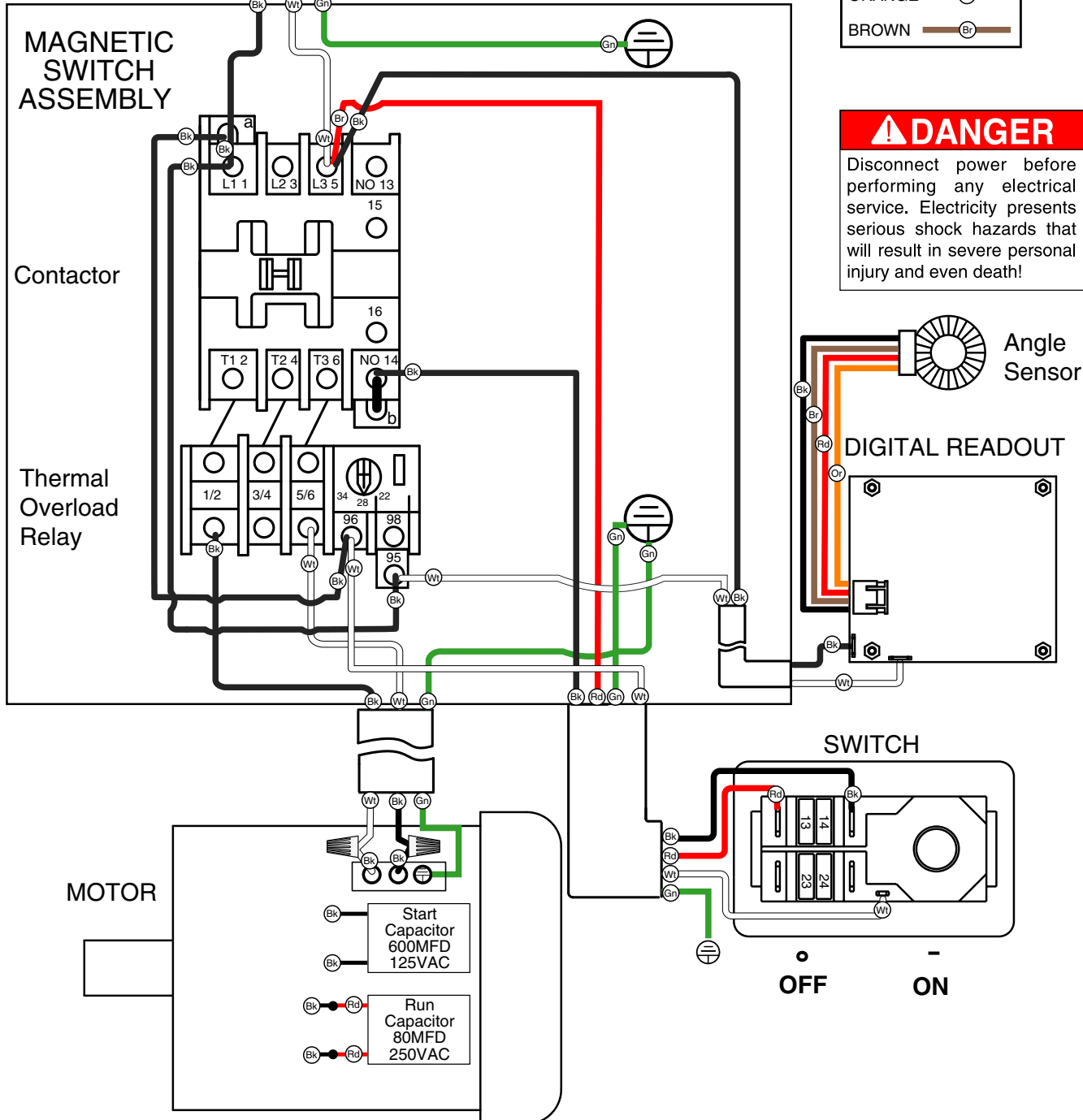

G0606X Electrical Components

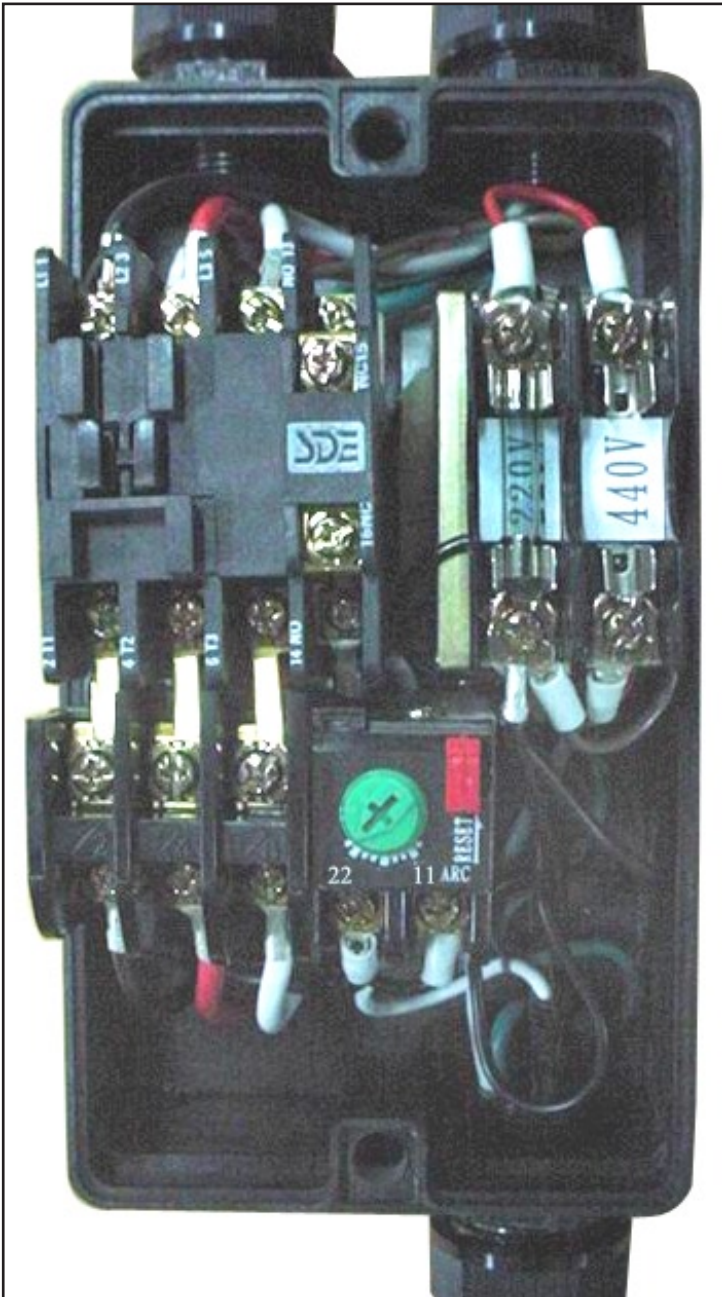

Figure 89. G0606X magnetic switch prewired to 220V, 3-phase.

Note: The thermal relay in **Figure 89** is set for 22 amp, 220V, 3-phase operation.

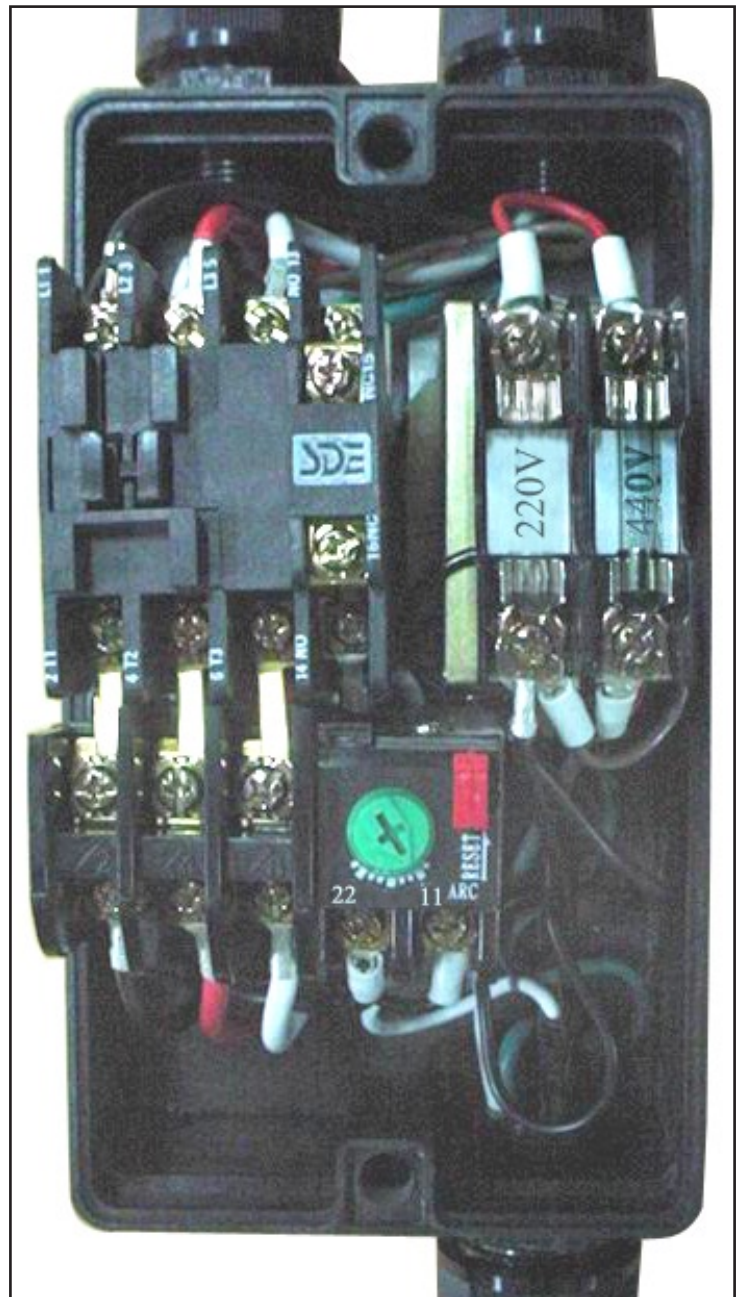
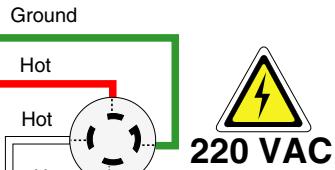

Figure 90. G0606X magnetic switch converted to 440V, 3-phase.

Note: The thermal relay in **Figure 90** is adjusted for 11 amp, 440V, 3-phase operation.



G0606X Wiring Diagram 220V



⚠ DANGER
Disconnect power before performing any electrical service. Electricity presents serious shock hazards that will result in severe personal injury and even death!

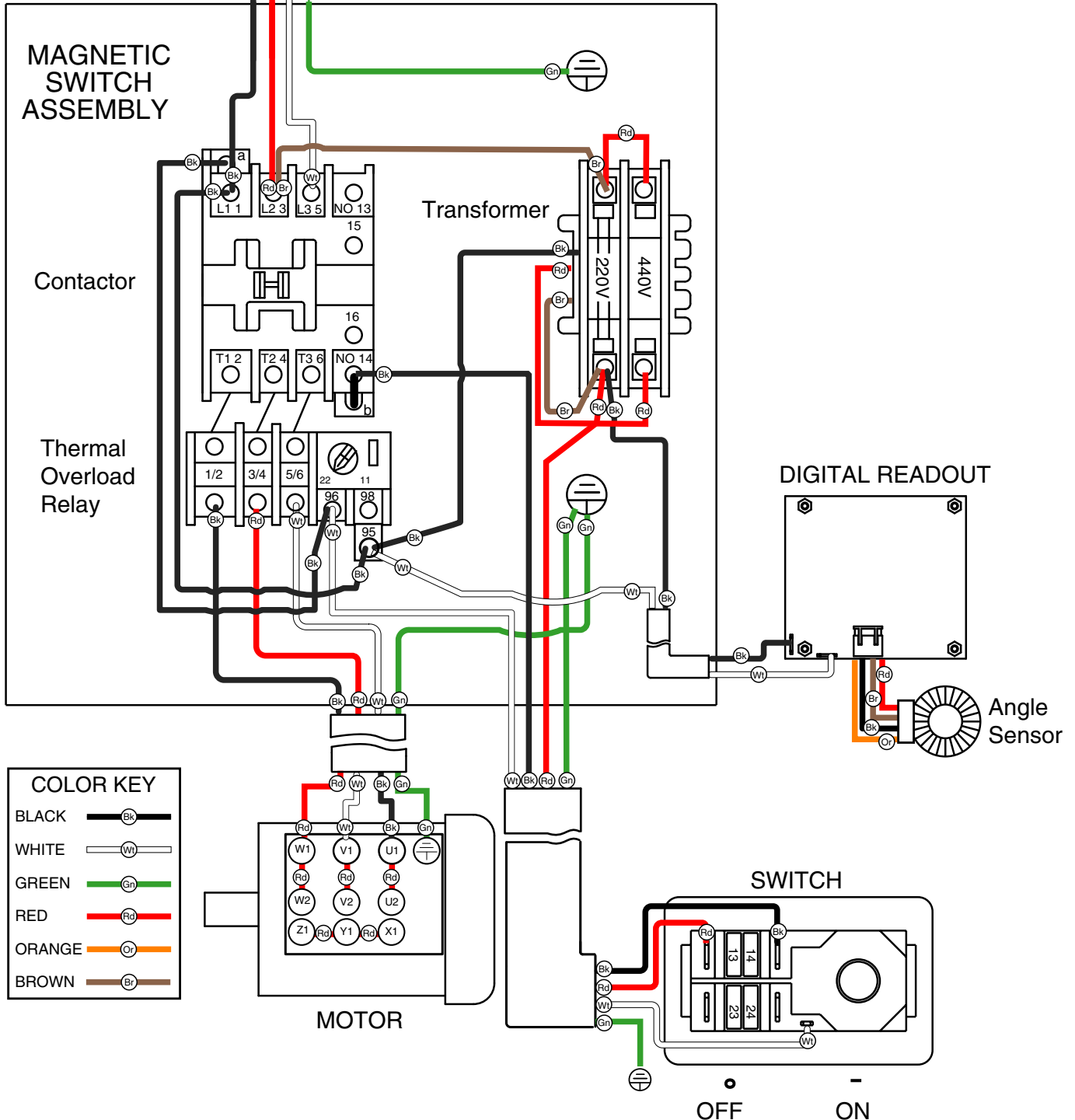

COLOR KEY

BLACK	— Bk —
WHITE	— Wt —
GREEN	— Gn —
RED	— Rd —
ORANGE	— Or —
BROWN	— Br —



G0606X Wiring Diagram 440V



**3-PHASE
440 VAC**

⚠ DANGER
Disconnect power before performing any electrical service. Electricity presents serious shock hazards that will result in severe personal injury and even death!

**DISCONNECT SWITCH
(as recommended)**

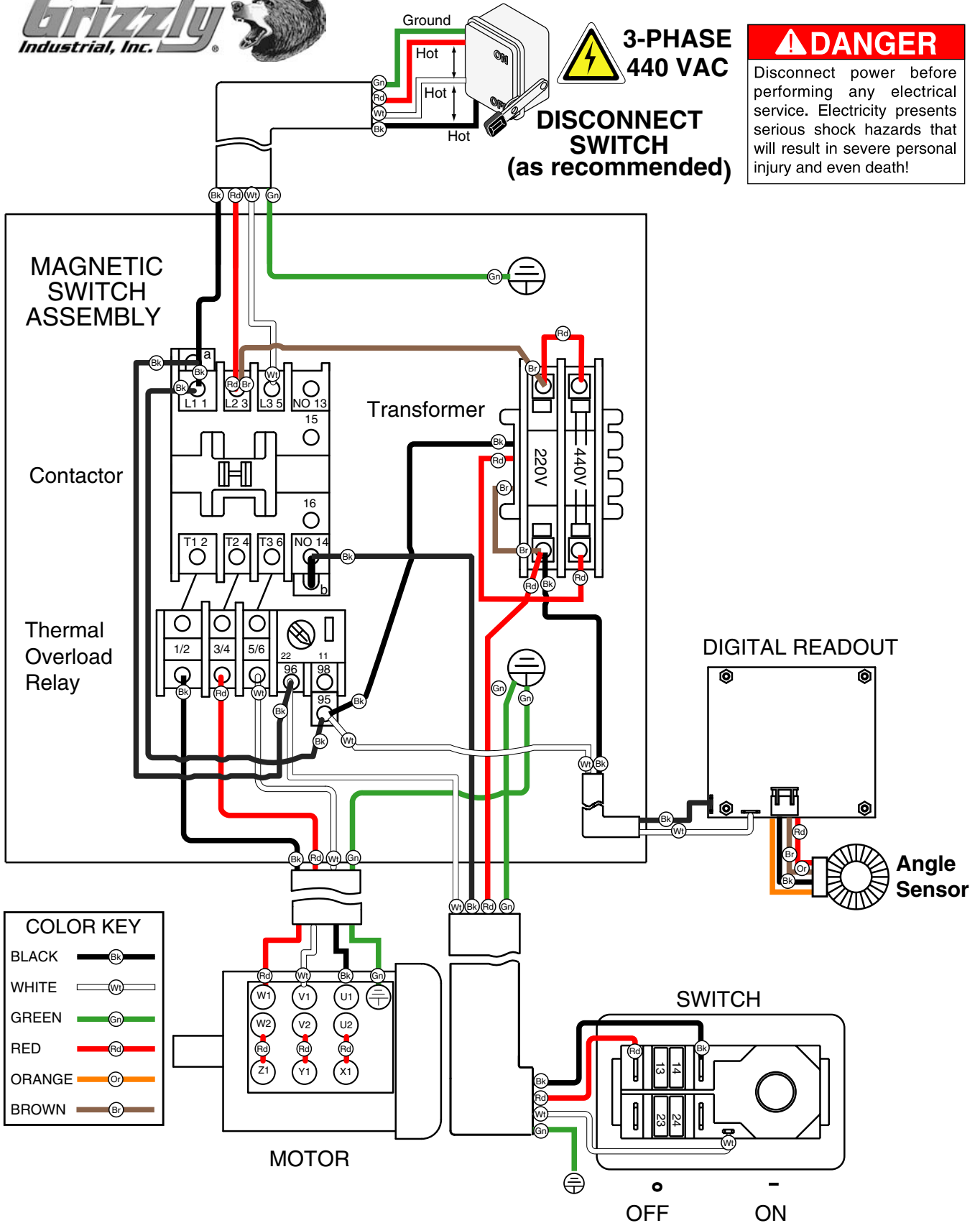

COLOR KEY

BLACK	— Bk —
WHITE	— Wh —
GREEN	— Gr —
RED	— Rd —
ORANGE	— Or —
BROWN	— Br —



Cabinet, Motor & Main Table Breakdown

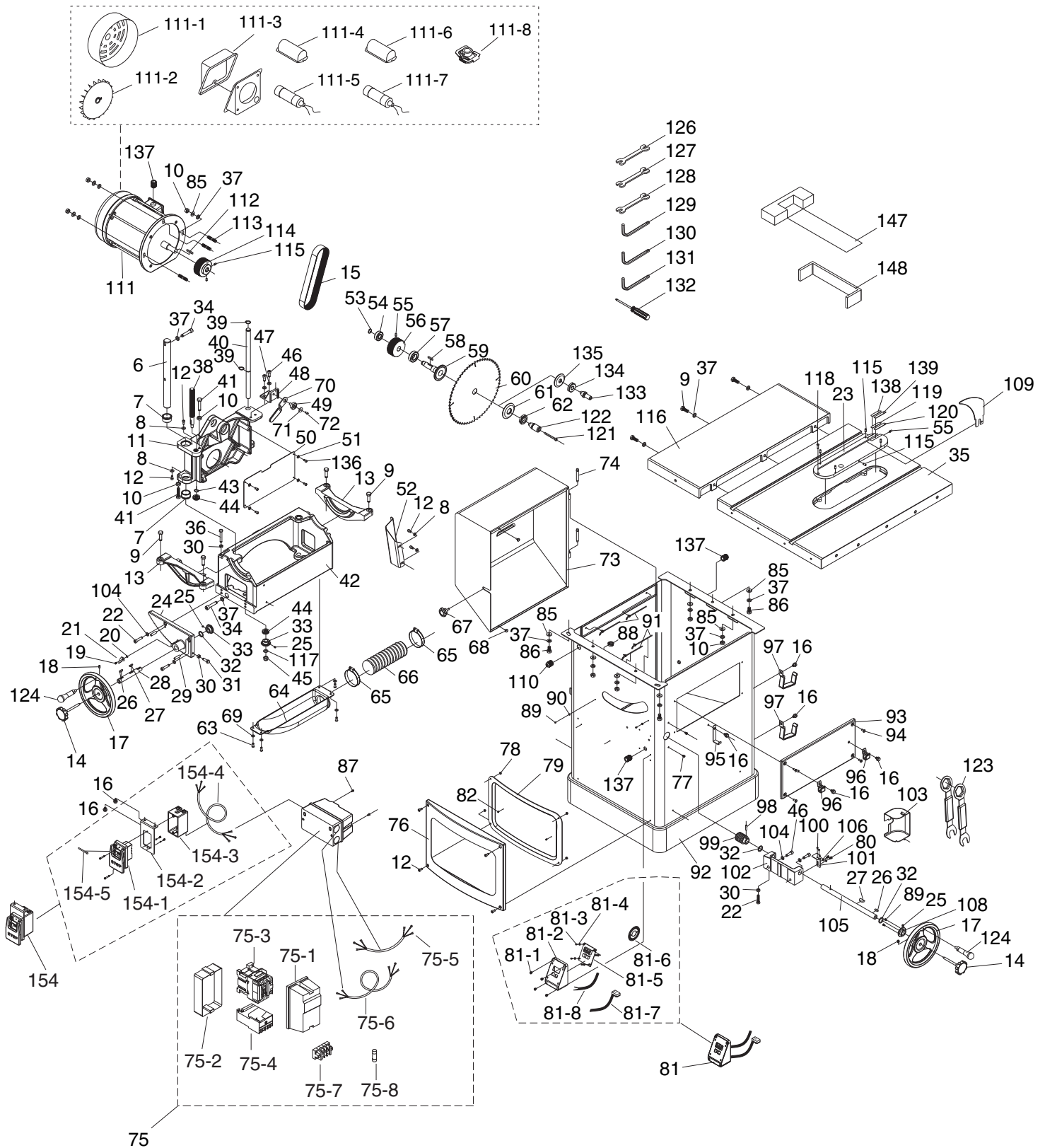

Cabinet, Motor & Main Table Parts List

REF PART #	DESCRIPTION
6	P0605X006 SHAFT
7	P0605X007 BUSHING
8	PW03M FLAT WASHER 6MM
9	PB14M HEX BOLT M10-1.5 X 35
10	PN02M HEX NUT M10-1.5
11	P0605X011 MOTOR MOUNTING BRACKET
12	PSB26M CAP SCREW M6-1 X 12
13	P0605X013 TRUNNION SLIDE
14	P0605X014 HANDWHEEL LOCK KNOB
15	P0605X015 FLAT BELT 250J-12
16	PFB15M FLANGE BOLT M8-1.25 X 12
17	P0605X017 HANDWHEEL
18	PSS17 SET SCREW 5/16-18 X 5/16
19	PSBS09M BUTTON HD CAP SCR M6-1 X 12
20	PTLW05M EXT TOOTH WASHER 6MM
21	P0605X021 POINTER
22	PSB13M CAP SCREW M8-1.25 X 30
23	P0605X023 TABLE INSERT
24	P0605X024 PLATE
25	PSS07M SET SCREW M5-.8 X 5
26	PK14M KEY 5 X 5 X 18
27	P0605X027 WOODRUFF KEY 22 X 5 X 6.5
28	P0605X028 SHAFT
29	PRP65M ROLL PIN 8 X 20
30	PN03M HEX NUT M8-1.25
31	PB07M HEX BOLT M8-1.25 X 25
32	P0605X032 FLAT WASHER 19MM
33	P0605X033 BEVEL GEAR
34	PSB143M CAP SCREW M10-1.5 X 50
35	P0605X035 TABLE
36	PB30M HEX BOLT M8-1.25 X 55
37	PLW06M LOCK WASHER 10MM
38	P0605X038 ACME SCREW
39	P0605X039 EXT RET RING 18MM
40	P0605X040 SHAFT
41	PB31M HEX BOLT M10-1.5 X 40
42	P0605X042 TRUNNION
43	PR54M INT RETAINING RING 15MM
44	P51102 THRUST BEARING 51102
45	PLN10M LOCK NUT M10-1.25
46	PSB31M CAP SCREW M8-1.25 X 25
47	PW01M FLAT WASHER 8MM

REF PART #	DESCRIPTION
48	P0605X048 SPLITTER MOUNTING BRACKET
49	P0605X049 SPECIAL BOLT
50	P0605X050 BELT COVER PLATE
51	PLW03M LOCK WASHER 6MM
52	P0605X052 DEFLECTOR PLATE
53	PR18M EXT RETAINING RING 17MM
54	P6203 BALL BEARING 6203ZZ
55	PSS91M SET SCREW M6-1 X 14
56	P0605X056 PULLEY
57	P6005 BALL BEARING 6005ZZ
58	PK131M KEY 5 X 5 X 28
59	P0605X059 SHAFT
60	P0605X060 BLADE
61	P0605X061 BLADE WASHER
62	P0605X062 BLADE NUT
63	PSB01M CAP SCREW M6-1 X 16
64	P0605X064 DUST CHUTE
65	P0605X065 HOSE CLAMP
66	P0605X066 DUST CHUTE HOSE 63MM x 1000MM
67	P0605X067 LOCK KNOB M6-1 X 17
68	P0605X068 BLOCK
69	PW03M FLAT WASHER 6MM
70	P0605X070 LEVER
71	PW02M FLAT WASHER 5MM
72	PSBS06M BUTTON HD CAP SCR M5-.8 X 12
73	P0605X073 MOTOR COVER
74	P0605X073 PIN 7 X 54
75	P0605X075 MAG SWITCH 5HP-1PH, 23A (G0605X)
75	P0606X075 MAG SWITCH 220V-3PH, 22A (G0606X)
75-1	P0605X075-1 MAG SWITCH FRONT COVER (G0605X)
75-1	P0606X075-1 MAG SWITCH FRONT COVER (G0606X)
75-2	P0605X075-2 MAG SWITCH BACK COVER (G0605X)
75-2	P0606X075-2 MAG SWITCH BACK COVER (G0606X)
75-3	P0605X075-3 CONTACTOR (G0605X)
75-3	P0606X075-3 CONTACTOR (G0606X)
75-4	P0605X075-4 THERMAL OVERLOAD RELAY (G0605X)
75-4	P0606X075-4 THERMAL OVERLOAD RELAY (G0606X)
75-5	P0605X075-5 MOTOR CORD 12AWG X 3C
75-5	P0606X075-5 MOTOR CORD 12AWG X 4C
75-6	P0605X075-6 POWER CORD 12AWG X 3C
75-6	P0606X075-6 POWER CORD 12AWG X 4C
75-7	P0606X075-7 TRANSFORMER (G0606X)



REF	PART #	DESCRIPTION
75-8	P0606X075-8	FUSE (G0606X)
76	P0605X076	FRONT COVER
77	PHTEK5M	TAP SCREW M4 X 12
78	PN06M	HEX NUT M5-.8
79	P0605X079	PLATE
80	PS05M	PHLP HD SCR M5-.8 X 8
81	P0605X080	DIGITAL READOUT ASSEMBLY
81-1	PS05M	PHLP HD SCR M5-.8 X 8
81-2	P0605X081-2	DIGITAL READOUT COVER
81-3	PS79M	PHLP HD SCR M3-.5 X 8
81-4	PW07M	FLAT WASHER 3MM
81-5	P0605X081-5	CIRCUIT BOARD
81-6	P0605X081-6	SENSOR PLATE
81-7	P0605X081-7	DATA CORD (SENSOR TO READOUT)
81-8	P0605X081-8	DIGITAL RDT. CORD 18AWG X 2C X 500MM (MAG SWITCH TO DIGITAL READOUT)
82	PS79M	PHLP HD SCR M3-.5 X 8
85	PW04M	FLAT WASHER 10MM
86	PB74M	HEX BOLT M10-1.5 X 20
87	P0605X087	NYLON SCREW 3/16-24 X 1/2
88	P0605X088	STRAIN RELIEF
89	PS17M	PHLP HD SCR M4-.7 X 6
90	PW05M	FLAT WASHER 4MM
91	P0605X091	CHAIN
92	P0605X092	BODY
93	P0605X093	RIGHT ACCESS PANEL
94	PFH40M	FLAT HD SCR M6-1 X 15
95	P0605X095	WRENCH MOUNTING BRACKET
96	P0605X096	MITER GAUGE MOUNTING BRACKET
97	P0605X097	FENCE RESTING BRACKET
98	PRP27M	ROLL PIN 5 X 28
99	P0605X099	SHAFT
100	PHTEK30M	TAP SCREW M3 X 6
101	P0605X101	"L" PLATE
102	P0605X102	BLADE TILT SHAFT BRACKET
103	P0605X103	COVER
104	PLW04M	LOCK WASHER 8MM
105	P0605X105	HANDWHEEL SHAFT
106	PW02M	FLAT WASHER 5MM
108	P0605X108	SPECIAL RING 19MM
109	P0605X109	RIVING KNIFE
110	P0605X110	STRAIN RELIEF
111	P0605X111	MOTOR 5HP, 1 PHASE (G0605X)
111	P0606X111	MOTOR 7.5HP, 3 PHASE (G0606X)
111-1	P0605X111-1	MOTOR FAN COVER (G0605X)

REF	PART #	DESCRIPTION
111-1	P0606X111-1	MOTOR FAN COVER (G0606X)
111-2	P0605X111-2	MOTOR FAN (G0605X)
111-2	P0606X111-2	MOTOR FAN (G0606X)
111-3	P0605X111-3	JUNCTION BOX (G0605X)
111-3	P0606X111-3	JUNCTION BOX (G0606X)
111-4	P0605X111-4	RUN CAPACITOR COVER (G0605X)
111-5	P0605X111-5	R. CAPACITOR 80MFD/ 250VAC (G0605X)
111-6	P0605X111-6	START CAPACITOR COVER (G0605X)
111-7	P0605X111-7	S. CAPACITOR 600MFD/125VAC (G0605X)
111-8	P0605X111-8	CENTRIFUGAL SWITCH (G0605X)
112	PK02M	KEY 5 X 5 X 40
113	P0605X113	SPECIAL MOTOR BOLT
114	P0605X114	MOTOR PULLEY
115	PSS01M	SET SCREW M6-1 X 10
116	P0605X116	EXTENSION WING
117	PW04M	FLAT WASHER 10MM
118	PFH54M	FLAT HD SCR M5-.8 X 20
119	P0605X119	LEFT TAPE
120	P0605X120	RIGHT TAPE
121	PSB49M	CAP SCREW M6-1 X 60
122	P0605X122	SPINDLE 1"
123	P0605X123	ARBOR WRENCH
124	P0605X124	HANDWHEEL HANDLE
126	PWR810	WRENCH 8 X 10
127	PWR1113	WRENCH 11 X 13
128	PWR1719	WRENCH 17 X 19
129	PAW04M	HEX WRENCH 4MM
130	PAW05M	HEX WRENCH 5MM
131	PAW06M	HEX WRENCH 6MM
132	P0605X132	PHLP HEAD SCREWDRIVER #1
133	P0605X133	SHAFT 5/8"
134	P0605X134	NUT 5/8-18
135	P0605X135	ARBOR FLANGE
136	PSBS09M	BUTTON HD CAP SCR M6-1 X 12
137	P0605X137	STRAIN RELIEF
138	P0605X138	LEFT PLATE
139	P0605X139	RIGHT PLATE
147	P0605X147	RAIL "T" PLATE
148	P0605X148	RAIL "U" PLATE
154	P0605X154	ON/OFF SWITCH ASSEMBLY
154-1	P0605X154-1	ON/OFF PUSH BUTTON SWITCH
154-2	P0605X154-2	ON/OFF SWITCH BRACKET
154-3	P0605X154-3	ON/OFF SWITCH BOX
154-4	P0605X154-4	ON/OFF SWICH CORD 14AWG X 3C
154-5	P0605X154-5	SAFETY PIN



Blade Guard Assembly Breakdown

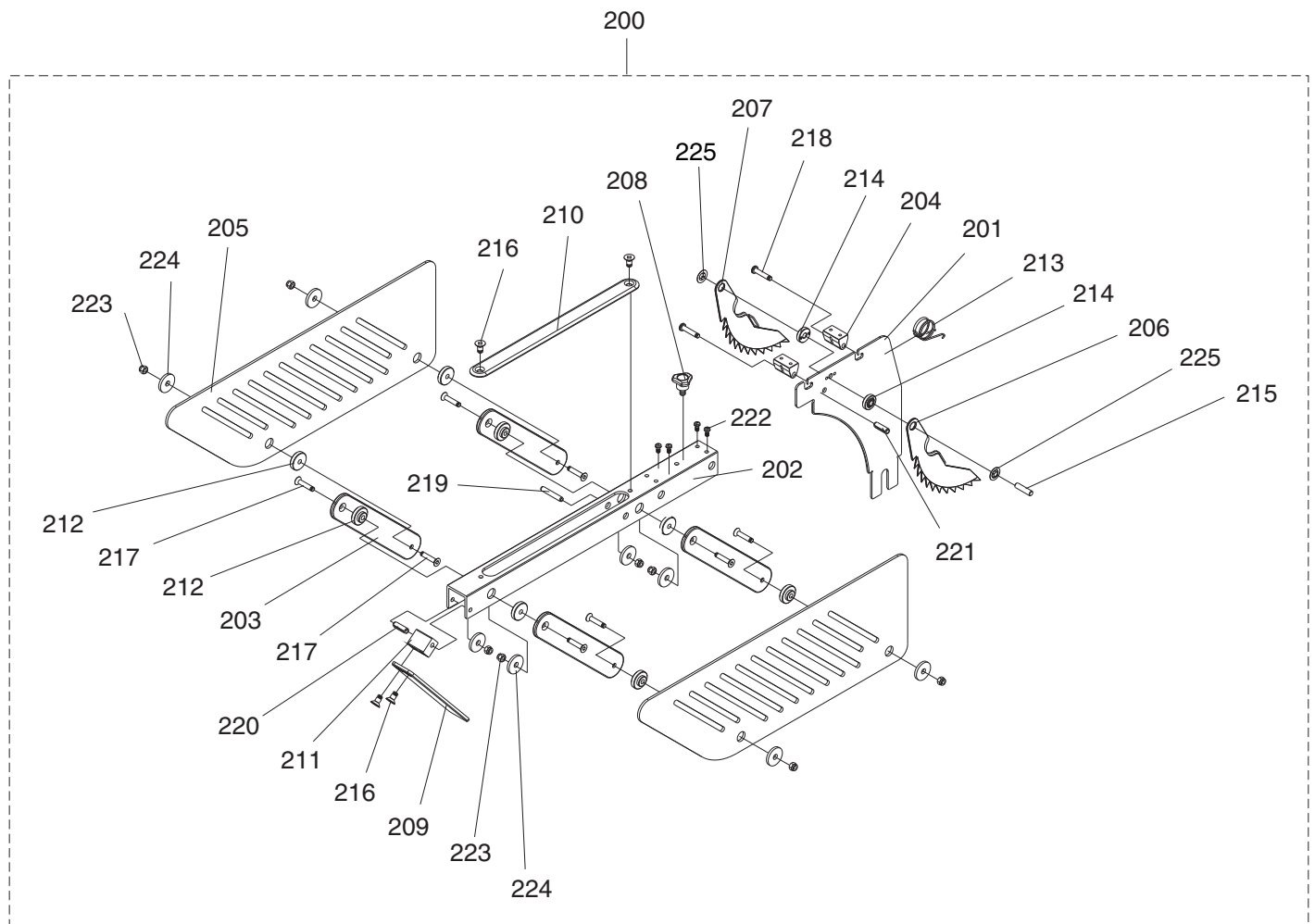

Blade Guard Parts List

REF	PART #	DESCRIPTION
200	P0605X200	BLADE GUARD ASSEMBLY
201	P0605X201	SPLITTER
202	P0605X202	SUPPORT
203	P0605X203	BLADE GUARD SWING BRACKET
204	P0605X204	BRACKET
205	P0605X205	BLADE GUARD COVER
206	P0605X206	RIGHT ANTI-BACK PAWL
207	P0605X207	LEFT ANTI-BACK PAWL
208	P0605X208	MITER GAUGE LOCK KNOB
209	P0605X209	FRONT COVER
210	P0605X210	UPPER COVER
211	P0605X211	BLOCK
212	P0605X212	SPACER

REF	PART #	DESCRIPTION
213	P0605X213	TORSION SPRING
214	P0605X214	RING 6MM
215	P0605X215	PIN 6 X 24
216	PFH43M	FLAT HD SCR M6-1 X 10
217	PFH54M	FLAT HD SCR M5-.8 X 20
218	PS22M	PHLP HD SCR M5-.8 X 25
219	PRP95M	ROLL PIN 8 X 55
220	PRP45M	ROLL PIN 5 X 32
221	PRP07M	ROLL PIN 6 X 20
222	PS07M	PHLP HD SCR M4-.7 X 8
223	PLN02M	LOCK NUT M5-.8
224	PW02M	FLAT WASHER 5MM
225	P0605X225	RING 6MM



Fence Assembly Breakdown

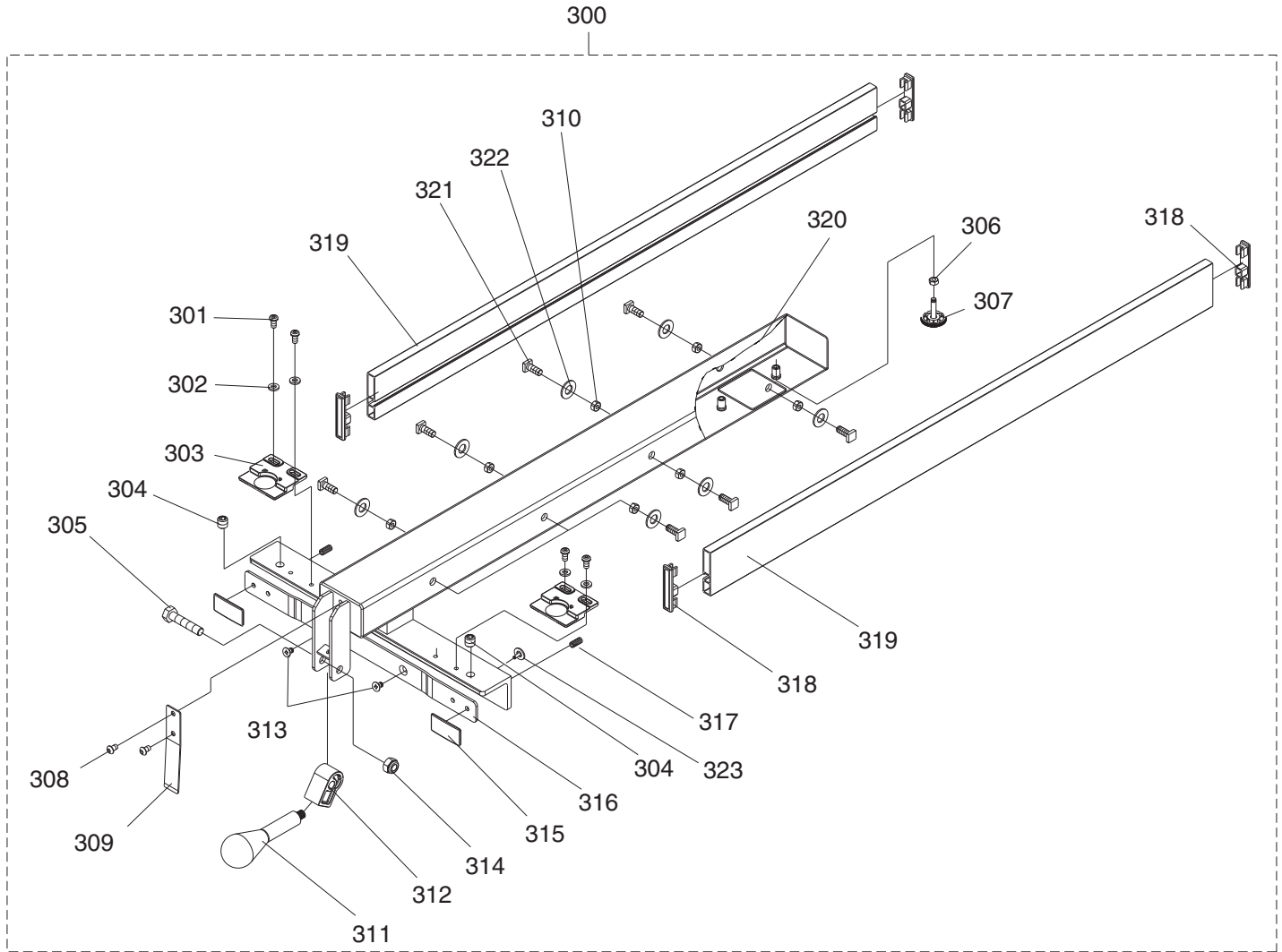

Fence Parts List

REF	PART #	DESCRIPTION
300	P0605X300	FENCE ASSEMBLY
301	PS68M	PHLP HD SCR M6-1 X 10
302	PW03M	FLAT WASHER 6MM
303	P0605X303	POINTER
304	P0605X304	PLASTIC SET SCREW
305	PB73M	HEX BOLT M10-1.5 X 50
306	PN01M	HEX NUT M6-1
307	P0605X307	REAR RAIL WHEEL
308	PSB26M	CAP SCREW M6-1 X 12
309	P0605X309	PLATE
310	PN03M	HEX NUT M8-1.25
311	P0605X311	FENCE HANDLE

REF	PART #	DESCRIPTION
312	P0605X312	CAM
313	PFH43M	FLAT HD SCR M6-1 X 10
314	PLN05M	LOCK NUT M10-1.5
315	P0605X315	PLATE
316	P0605X316	CLAMPING BRACKET
317	PSS20M	SET SCREW M8-1.25 X 8
318	P0605X318	PLATE CAP
319	P0605X319	FENCE PLATE
320	P0605X320	FENCE
321	P0605X321	T-BOLT M8-1.25 X 20
322	PW01M	FLAT WASHER 8MM
323	P0605X323	PLASTIC PAD



Miter Gauge Assembly Breakdown

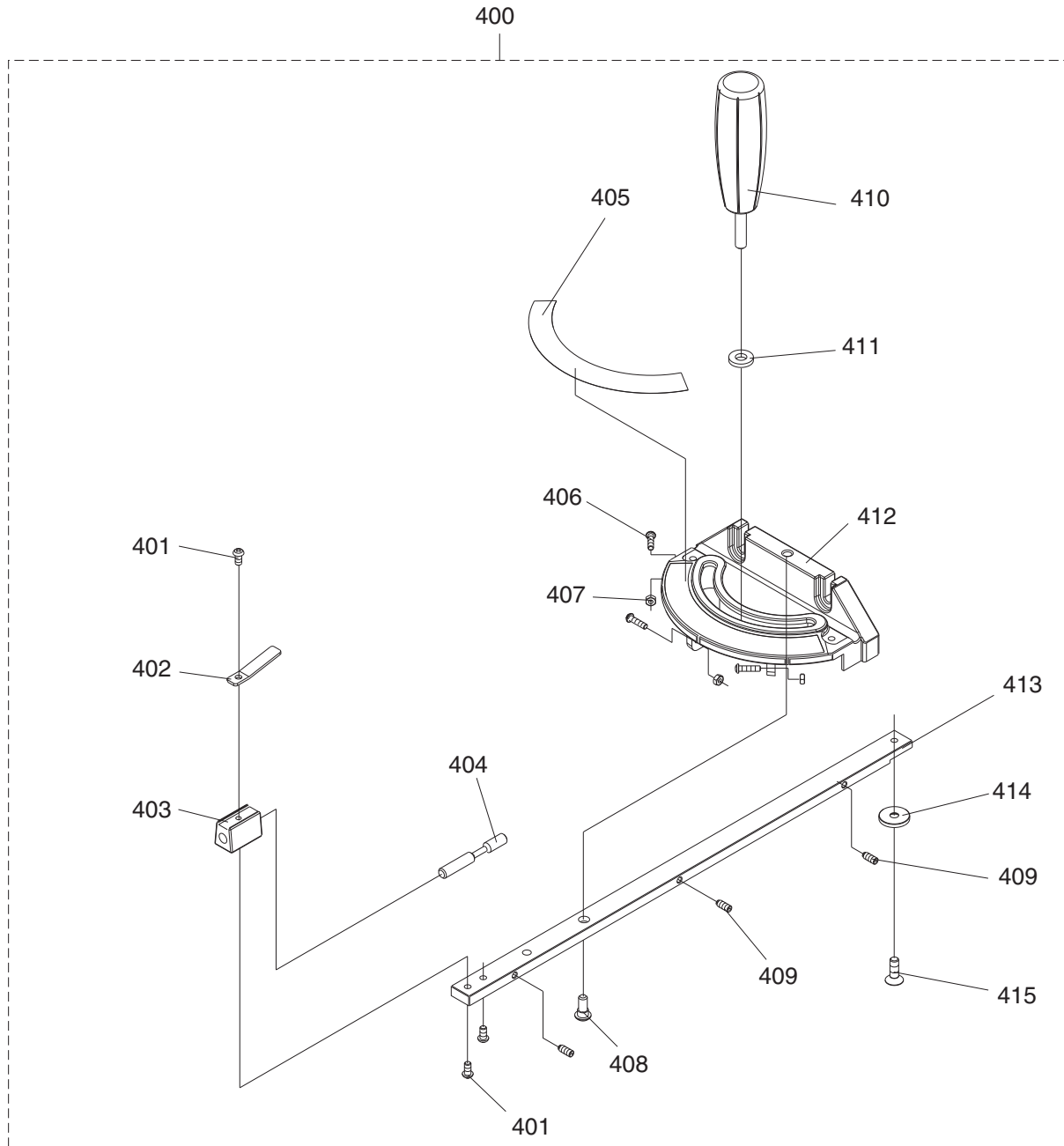

Miter Gauge Parts List

REF	PART #	DESCRIPTION
400	P0605X400	MITER GAUGE
401	PS06	PHLP HD SCR 10-24 X 3/8
402	P0605X402	POINTER
403	P0605X403	BLOCK
404	P0605X404	SHAFT
405	P0605X405	MITER GAUGE SCALE
406	P0605X406	PHLP HD SCR 5/32-32 X 5/8
407	P0605X407	HEX NUT 5/32-32

REF	PART #	DESCRIPTION
408	PS04	PHLP HD SCR 1/4-20 X 1/2
409	PSS53M	SET SCREW M5-.8 X 12
410	P0605X410	MITER GAUGE HANDLE
411	PW01M	FLAT WASHER 8MM
412	P0605X412	MITER GAUGE
413	P0605X413	PLATE
414	P0605X414	GUIDE PLATE
415	PFH9M	FLAT HD SCR M6-1 X 6



Extension Table Assembly Breakdown

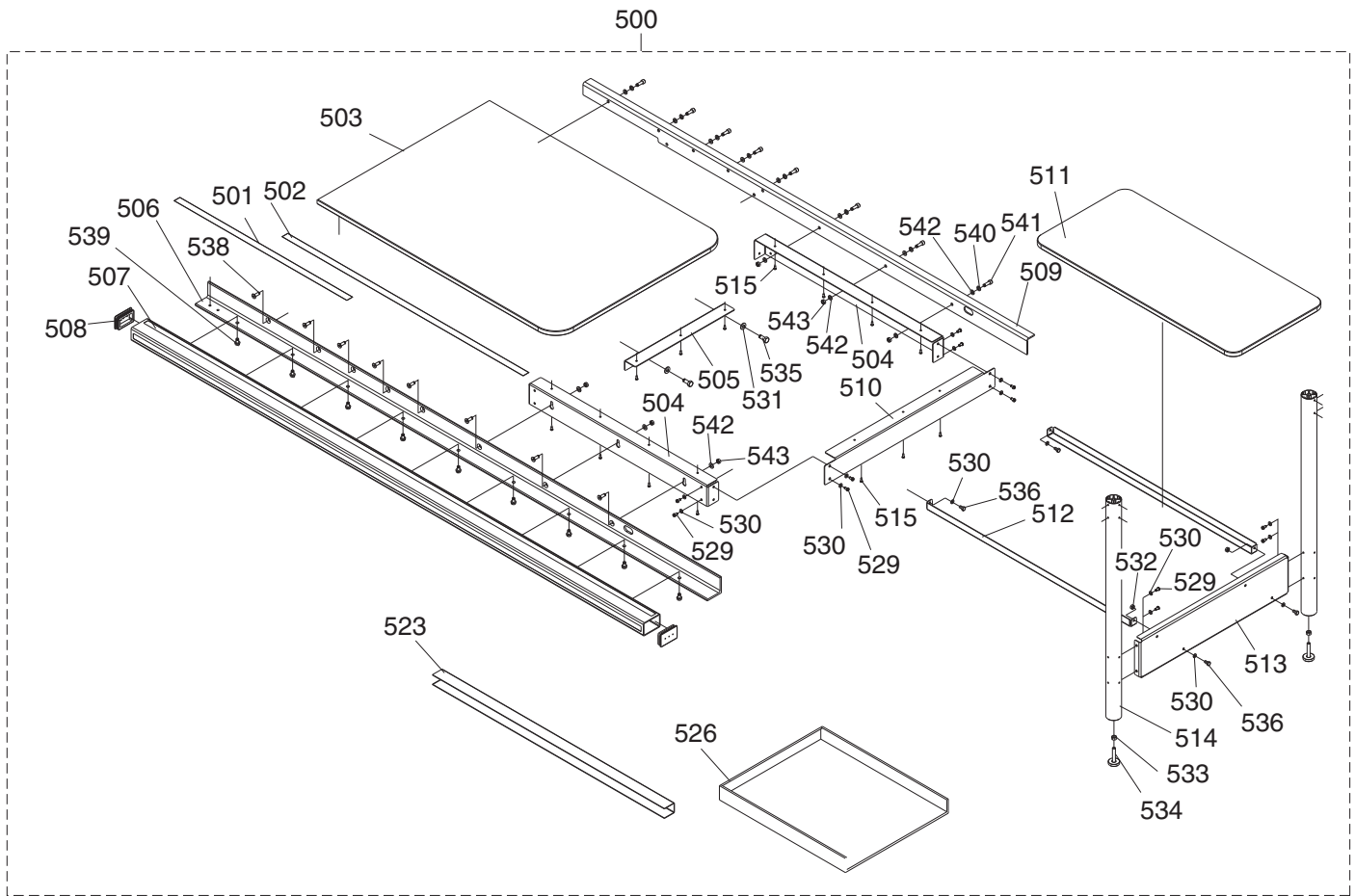

Extension Table Parts List

REF	PART #	DESCRIPTION
500	P0605X500	EXTENSION TABLE ASSEMBLY
501	P0605X501	LEFT SCALE
502	P0605X502	RIGHT SCALE
503	P0605X503	EXTENSION TABLE PLATE
504	P0605X504	EXTENSION TABLE SUPPORT
505	P0605X505	FRONT EXTENSION BRACKET
506	P0605X506	FRONT RAIL (91-3/8" LONG)
507	P0605X507	FENCE TUBE (91-3/8" LONG)
508	P0605X508	END CAP
509	P0605X509	REAR RAIL (79" LONG)
510	P0605X510	REAR EXTENSION BRACKET
511	P0605X511	LOWER SHELF
512	P0605X512	LOWER SHELF BRACKET
513	P0605X513	SHELF END PLATE
514	P0605X514	SUPPORT LEG
515	PHTEK6M	TAP SCREW M4 X 16

REF	PART #	DESCRIPTION
523	P0605X523	FRONT RAIL PLATE 52"
526	P0605X526	RIGHT EXTENSION PLATE
529	PS14M	PHLP HD SCR M6-1 X 12
530	PW03M	FLAT WASHER 6MM
531	PW04M	FLAT WASHER 10MM
532	PN01M	HEX NUT M6-1
533	PN08	HEX NUT 3/8-16
534	P0605X534	FOOT 3/8-16 X 2
535	PB32M	HEX BOLT M10-1.5 X 25
536	PS14M	PHLP HD SCR M6-1 X 12
538	PFH21M	FLAT HD SCR M8-1.25 X 25
539	PFB15M	FLANGE BOLT M8-1.25 X 12
540	PLW04M	LOCK WASHER 8MM
541	PSB31M	CAP SCREW M8-1.25 X 25
542	PW01M	FLAT WASHER 8MM
543	PN03M	HEX NUT M8-1.25



Outfeed Table Assembly Breakdown

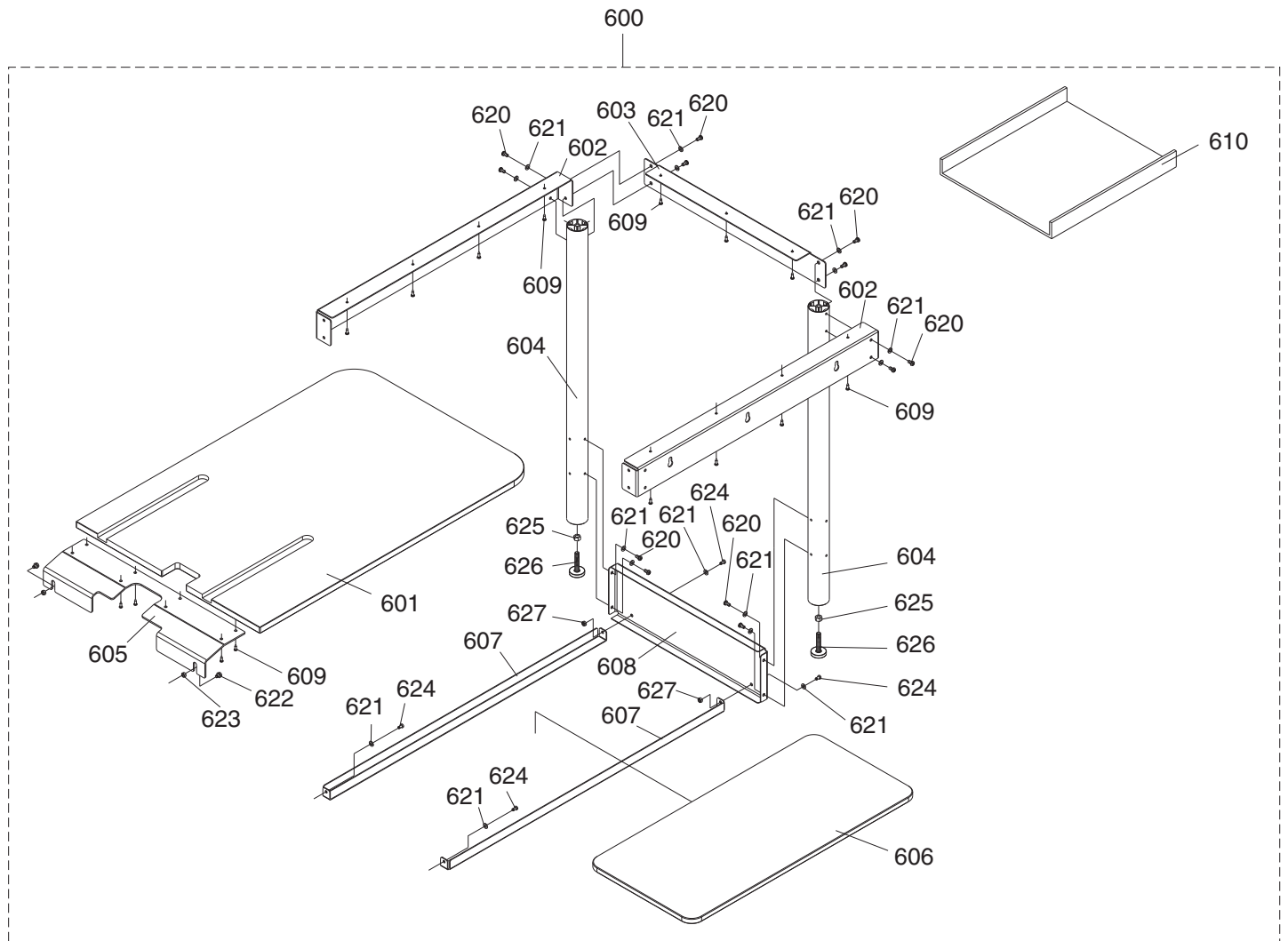

Outfeed Table Parts List

REF	PART #	DESCRIPTION
600	P0605X600	OUTFEED TABLE ASSEMBLY
601	P0605X601	OUTFEED TABLE PLATE
602	P0605X602	OUTFEED TABLE SUPPORT
603	P0605X603	REAR OUTFEED TABLE BRACKET
604	P0605X604	SUPPORT LEG
605	P0605X605	FRONT OUTFEED TABLE BRACKET
606	P0605X606	LOWER SHELF
607	P0605X607	LOWER SHELF BRACKET
608	P0605X608	SHELF END PLATE
609	PHTEK6M	TAP SCREW M4 X 16

REF	PART #	DESCRIPTION
610	P0605X610	REAR EXTENSION PLATE
620	PS14M	PHLP HD SCR M6-1 X 12
621	PW03M	FLAT WASHER 6MM
622	PFB16M	FLANGE BOLT M8-1.25 X 16
623	PN03M	HEX NUT M8-1.25
624	PS14M	PHLP HD SCR M6-1 X 12
625	PN08	HEX NUT 3/8-16
626	P0605X626	FOOT 3/8-16 X 2
627	PN01M	HEX NUT M6-1



Warning Label Parts List

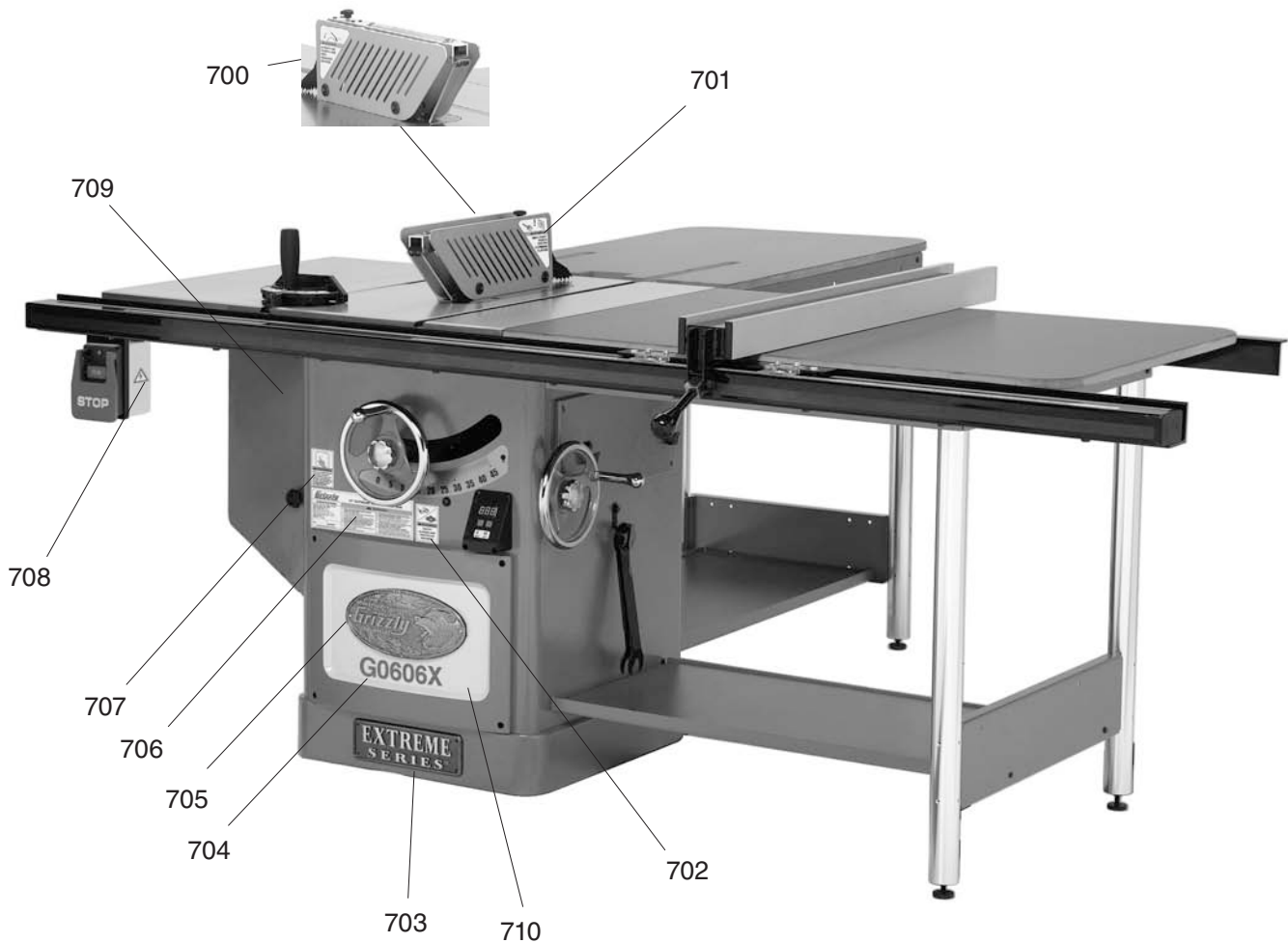

REF	PART #	DESCRIPTION
700	P0605X700	GUARD AND ANTI-KICK BACK LABEL
701	P0605X701	DISCONNECT POWER-BLADES LABEL
702	P0605X702	SAFETY GLASSES-HEARING LABEL
703	H7942	EXTREME SERIES PLATE
704	P0605X704	MODEL NUMBER LABEL G0605X
704	P0606X704	MODEL NUMBER LABEL G0606X
705	G8589	GRIZZLY NAMEPLATE-LARGE

REF	PART #	DESCRIPTION
706	P0605X706	MACHINE ID LABEL G0605X
706	P0606X706	MACHINE ID LABEL G0606X
707	PLABEL-12A	READ MANUAL-VERTICAL NS 7/05
708	PLABEL-14	ELECTRICITY LABEL
709	PPAINT-1	GRIZZLY GREEN PAINT
710	PPAINT-11	PUNITY TOUCH-UP PAINT

WARNING

Safety labels warn about machine hazards and ways to prevent injury. The owner of this machine **MUST** maintain the original location and readability of the labels on the machine. If any label is removed or becomes unreadable, **REPLACE** that label before using the machine again. Contact Grizzly at (800) 523-4777 or www.grizzly.com to order new labels.



WARRANTY AND RETURNS

Grizzly Industrial, Inc. warrants every product it sells for a period of **1 year** to the original purchaser from the date of purchase. This warranty does not apply to defects due directly or indirectly to misuse, abuse, negligence, accidents, repairs or alterations or lack of maintenance. This is Grizzly's sole written warranty and any and all warranties that may be implied by law, including any merchantability or fitness, for any particular purpose, are hereby limited to the duration of this written warranty. We do not warrant or represent that the merchandise complies with the provisions of any law or acts unless the manufacturer so warrants. In no event shall Grizzly's liability under this warranty exceed the purchase price paid for the product and any legal actions brought against Grizzly shall be tried in the State of Washington, County of Whatcom.

We shall in no event be liable for death, injuries to persons or property or for incidental, contingent, special, or consequential damages arising from the use of our products.

To take advantage of this warranty, contact us by mail or phone and give us all the details. We will then issue you a "Return Number," which must be clearly posted on the outside as well as the inside of the carton. We will not accept any item back without this number. Proof of purchase must accompany the merchandise.

The manufacturers reserve the right to change specifications at any time because they constantly strive to achieve better quality equipment. We make every effort to ensure that our products meet high quality and durability standards and we hope you never need to use this warranty.

Please feel free to write or call us if you have any questions about the machine or the manual.

Thank you again for your business and continued support. We hope to serve you again soon.





WARRANTY CARD

Name _____
 Street _____
 City _____ State _____ Zip _____
 Phone # _____ Email _____ Invoice # _____
 Model # _____ Order # _____ Serial # _____

The following information is given on a voluntary basis. It will be used for marketing purposes to help us develop better products and services. **Of course, all information is strictly confidential.**

1. How did you learn about us?

Advertisement Friend Catalog
 Card Deck Website Other:

2. Which of the following magazines do you subscribe to?

<input type="checkbox"/> Cabinetmaker & FDM	<input type="checkbox"/> Popular Science	<input type="checkbox"/> Wooden Boat
<input type="checkbox"/> Family Handyman	<input type="checkbox"/> Popular Woodworking	<input type="checkbox"/> Woodshop News
<input type="checkbox"/> Hand Loader	<input type="checkbox"/> Precision Shooter	<input type="checkbox"/> Woodsmith
<input type="checkbox"/> Handy	<input type="checkbox"/> Projects in Metal	<input type="checkbox"/> Woodwork
<input type="checkbox"/> Home Shop Machinist	<input type="checkbox"/> RC Modeler	<input type="checkbox"/> Woodworker West
<input type="checkbox"/> Journal of Light Cont.	<input type="checkbox"/> Rifle	<input type="checkbox"/> Woodworker's Journal
<input type="checkbox"/> Live Steam	<input type="checkbox"/> Shop Notes	<input type="checkbox"/> Other:
<input type="checkbox"/> Model Airplane News	<input type="checkbox"/> Shotgun News	
<input type="checkbox"/> Old House Journal	<input type="checkbox"/> Today's Homeowner	
<input type="checkbox"/> Popular Mechanics	<input type="checkbox"/> Wood	

3. What is your annual household income?

\$20,000-\$29,000 \$30,000-\$39,000 \$40,000-\$49,000
 \$50,000-\$59,000 \$60,000-\$69,000 \$70,000+

4. What is your age group?

20-29 30-39 40-49
 50-59 60-69 70+

5. How long have you been a woodworker/metalworker?

0-2 Years 2-8 Years 8-20 Years 20+ Years

6. How many of your machines or tools are Grizzly?

0-2 3-5 6-9 10+

7. Do you think your machine represents a good value? Yes No

8. Would you recommend Grizzly Industrial to a friend? Yes No

9. Would you allow us to use your name as a reference for Grizzly customers in your area?

Note: We never use names more than 3 times. Yes No

10. Comments: _____

CUT ALONG DOTTED LINE

FOLD ALONG DOTTED LINE



Place
Stamp
Here



GRIZZLY INDUSTRIAL, INC.
P.O. BOX 2069
BELLINGHAM, WA 98227-2069



FOLD ALONG DOTTED LINE

Send a Grizzly Catalog to a friend:

Name _____
Street _____
City _____ State _____ Zip _____

TAPE ALONG EDGES--PLEASE DO NOT STAPLE

grizzly.com[®]

TOOL WEBSITE

Buy Direct and Save with Grizzly[®] – Trusted, Proven and a Great Value!
~Since 1983~

*Visit Our Website Today For
Current Specials!*

**ORDER
24 HOURS A DAY!
1-800-523-4777**

